

**Mr Blue 2.0**
ESSILOR EDGER



User Manual

CONTENTS

INTRODUCTION	7
I. FIRST STEPS WITH MR. BLUE 2.0	9
1. Descriptive diagrams	11
2. Using the edger	13
a. Turning on the edger	13
b. Switching off the edger	14
c. Using the touch screen and keypads	14
d. Edging screen	15
II. EDGING A LENS	17
1. Edger working environment	19
a. Menu screen	19
b. Calling up a shape	21
c. Lens set-up and feeling	21
2. Perform a Beveling	23
a. Automatic beveling	24
b. Legend screen for customized bevels	25
c. Customized beveling	26
d. Modifying the bevel curve	27
e. Modifying the bevel curve at a particular point	27
f. Displacing the bevel curve	28
3. High-base beveling	28
a. Captioned screens	29
b. High-base beveling	31
4. Perform a Step beveling (option)	35
a. Mounting of the step bevel tool	37
b. Captioned screens	40
c. Adjusting the Step bevel finish	41
d. Perform a Step bevel	46
5. Grooving	50
a. Automatic grooving	51
b. Customized groove legend screen	51
c. Customized grooving	53
d. Modifying the groove curve	54
e. Modifying a point in the groove curve	54
f. Displacement of the groove curve	55
6. Flat-edge finishing	55
7. Mixed job	56
a. Legend screens	56
b. Configuring the mixed finish	57
8. Drilled job	58
a. Automatic drilling	59
b. Legend screen for customized drilling	60
c. Customized drilling	61
9. Polishing	61
10. Chamfering	62
11. Perform a Retouching	63
III. CONFIGURING THE EDGER	65

1. Configure the edger	67
a. Time, date and language	67
b. Connections	68
c. Screensaver	68
2. Adjusting the precision of the edger	68
a. Adjusting the diameter of the finished lenses	69
b. Adjusting the position of the bevel and groove	70
c. Adjusting the diameter of drill-holes	70
d. Adjusting the chamfer	71
e. Adjusting the groove	72
f. To adjust the engraving	72
g. Adjust the position of high-base bevel	73
h. Adjust the position of the step bevel	74
3. Restore the factory settings	75
IV. MAINTENANCE & SERVICING	77
1. Carrying out the autotests	79
2. Calibrating the touch screen	80
3. Consult the preventive maintenance screen of the “small tools” module	80
4. Changing or cleaning the edger tools	82
a. Changing or cleaning the mill bit	83
b. Changing or cleaning the drill bit	84
c. Changing the engraving tip	86
5. Statistics and technical log	88
a. Edger cycles	88
b. Technical history and errors	90
6. Maintaining and cleaning the edger	90
a. Precautions required	90
b. Clean the door, the GMD module and the wheels (high-base and step bevel)	91
c. Dressing the wheels	91
V. USING TO M'EYE SIGN	93
1. To activate to M'EYE Sign	95
2. To carry out an engraving	97
a. To prepare the engraving	97
b. Performing engraving	107
c. Setting up the favorites	111
3. To produce a creative shape	112
a. On Essibox	112
b. On the edger	119
TECHNICAL DATA	121
1. Edger	122
2. Environment	123
GENERAL INFORMATION	125
1. Symbols	126
2. Modifications	126
3. Declaration of conformity	126
4. Copyright	126
5. Materials and products	126
6. Safety instructions:	127
7. Electromagnetic waves	127
8. License agreement for M'EYE Sign™ (Engraving) software	127

a. General information	127
b. Accepted use of the Software and restrictions	127
c. Liability	127
d. Disclaimer of warranties	128
e. Limited liability	128
f. Termination	128
g. Applicable law	128
h. Entirety of the agreement; authentic language	128
GLOSSARY	129

INTRODUCTION

To benefit fully from the functions of your Mr Blue 2.0 edger, we advise you to consult the entirety of this document.

You have memory version: V9.0.0.

Addition of the Step Bevel function.

This function allows you to produce specific bevels adapted to the frames that have an asymmetrical groove.

I. FIRST STEPS WITH MR. BLUE 2.0

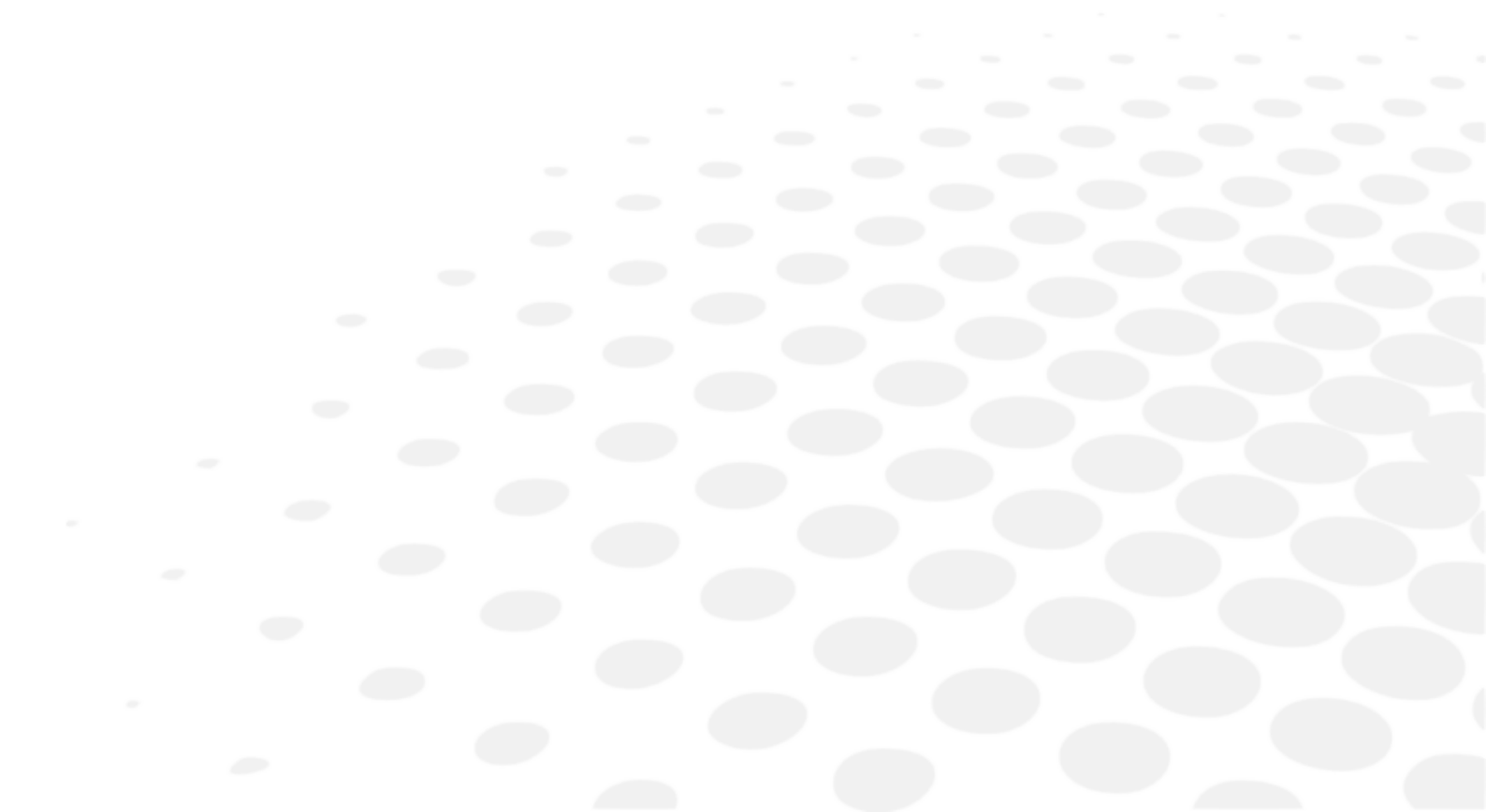

This chapter contains all the information relating to the first use of the edger:

- Description of the edger (p.11)
- Using the device (p.13)

1. Descriptive diagrams

This section consists of descriptions and lists of accessories.

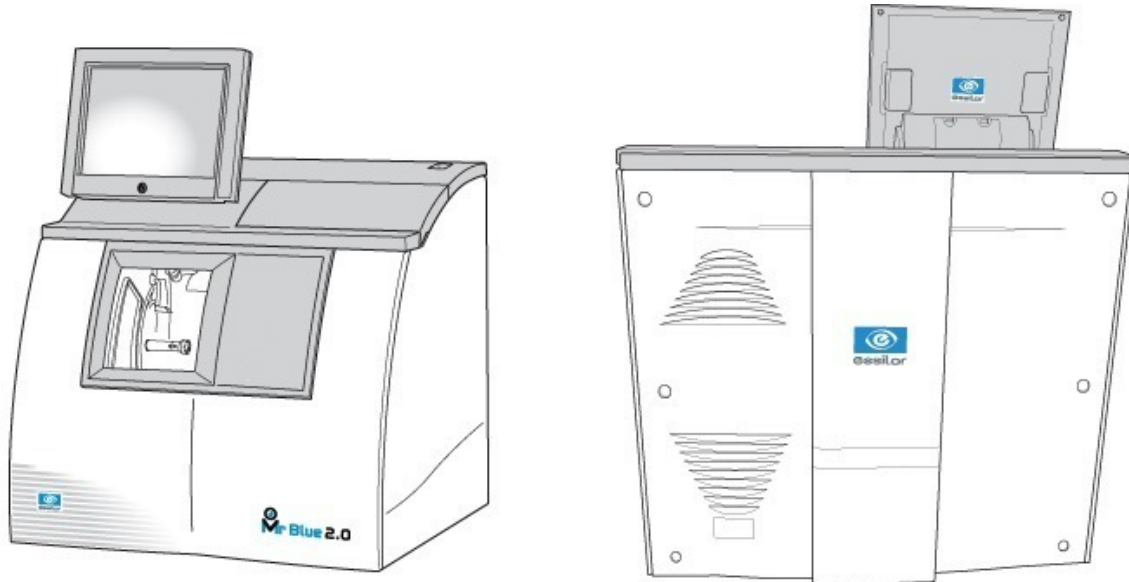

1. Screen
2. ON/OFF button
3. Trough
4. Main switch
5. Service accessory/Connector hatch
6. Operating accessory hatch
7. Screen tilt buttons
8. Fans
9. Cable cover
10. Manufacturer plate

Connectors

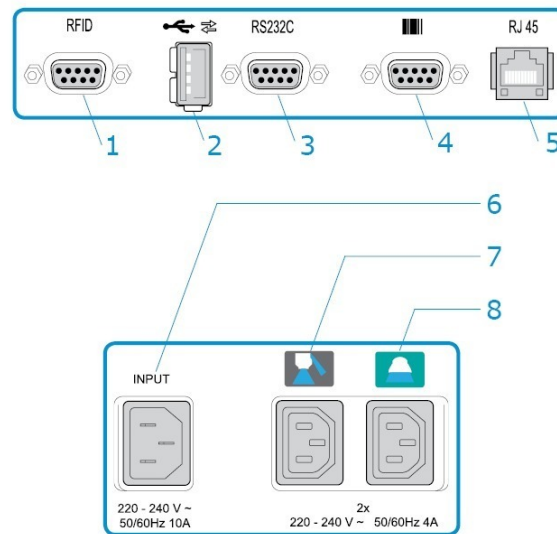

1. RFID port
2. USB port
3. Serial port
4. Barcode reader port
5. Ethernet port
6. Power socket
7. Solenoid valve socket
8. Pump socket (tank + pump) / Solenoid valve socket (town)

Accessories

- Protective cover
- Transport wedges to be kept

Operating accessory hatch

- Stylus
- 22 mm posiblock holder
- 18 x 14 mm posiblock holder
- 22 mm stop
- 18 x 14 mm stop
- Unblocking clamp
- Mill/drill bit replacement tool
- Ø 1.0 mm drill bit (mounted on the module)
- Ø 0.8 mm drill bit
- Ø 1.2 mm edging mill bit (quantity 2, including one mounted on the module)
- Ø 20 mm grooving wheel (mounted on the module)
- Tri-material chamfering wheel (mounted on the module)
- Engraving tip
- Posiblock handling goblets (quantity 2)

Service accessory hatch

- Orange dressing stone for glass roughing wheel

- White dressing stone for finishing wheel
- Square dressing stone for polishing wheel
- Grooving wheel replacement tool
- Allen key for tool change
- Open-ended spanner for tool change
- Drill-head tool for changing the engraving tip
- Allen key for changing the engraving attachment

Options

- Step bevel kit
- Barcode reader
- Roll of barcode labels
- Open or closed circuit spraying kit
- Milling chip recovery tray
- Recovery tank

Connection accessories



- 220 V power cable
- RJ45 cable for the tracer-edger connection
- Essibox connection cable
- Wastewater evacuation pipe with attachment ring

2. Using the edger

In this section, you will find all the information concerning the following:

- Turning on (p.13) and off (p.14) the edger,
- the use of the touch screen and the keyboards (p.14),
- the description of the work screens of the edger (p.15).



a. Turning on the edger

- 1 To switch on the edger, press the main switch located on the top of the machine.
- 2 Press the ON/OFF buttons  located under the touch screen.
 - > The edger will initialise.
- 3 On the edger screen, press the icon  to complete the initialisation phase.
 - > A beep indicates that initialization was successful.
The edger is ready for use when the initial screen is displayed.

b. Switching off the edger

1 Before switching off the edger:

- Check that there is no glass in the trough
- Check that the lens clamp shafts are loosened and that the trough door is open
- Select the edging screen

2 Briefly press the ON/OFF button  located under the touch screen or press , then .



Do not press the ON/OFF button for several seconds. This would result in a shut-down of the machine and an error message would be displayed at the next switch-on.

> A confirmation message is displayed on the screen.

3 Press  to confirm.

> The edger will switch off.



Extended period of non-use

For a prolonged period of non-use (a few days), it is preferable to turn off the edger using the main switch.

c. Using the touch screen and keypads

Using the touch screen

Use the stylus supplied with the machine to use the touch screen.



After each use, place the stylus on the stylus rest, represented by an oval sticker.

You can also touch the screen with your finger.

- If the screen is not sensitive enough to finger pressure, press lightly with a fingernail.
- If the response area does not correspond to the position of the key, you need to calibrate the touch screen. For more information, refer to the following section [Maintenance and servicing > Checks and calibration > Calibrating the touch screen \(p.80\)](#).



- Never press hard on the screen as this could break it.
- Never press on the screen with sharp objects such as pens, scissors, clamps, etc.
- Screen breakage is not covered by the guarantee.



On the screen, press the icon-buttons to access the menus and job functions required.



Using the keypads

When you need to input or modify data, two types of keypads are automatically displayed, according to the information to be input.





- The numeric keypad is displayed for the input of values.



-  Reset the fields
-  Back

-  Confirm
-  Cancel and go back to the work screen
- The alphanumeric keypad is displayed to save or search for jobs.



-  Job ID
-  Job reference (alphanumeric characters)
-  list jobs ^(p.130)
-  Collection list

d. Edging screen

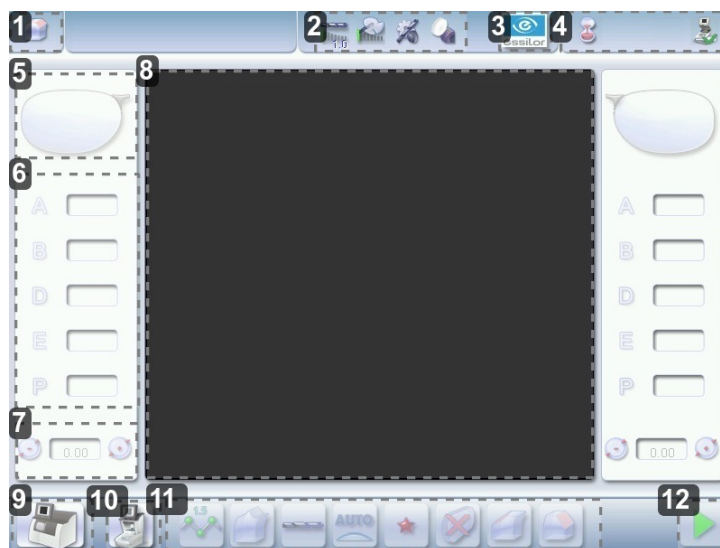

1. Work screen indicator
2. Tool wear indicators
3. Settings
4. Devices connected
5. Active eye
6. Information on the shape
7. Size increase/reduction
8. Work area
9. Turning off the product/edging screen/engraving screen
10. Job call: Tracer menu
11. Actions available for the current screen
12. Start the edging cycle

**Detailed functions**

For more information, consult the section Edging a lens > Work environment of the edger > Captioned screen. (p. 19)

II. EDGING A LENS

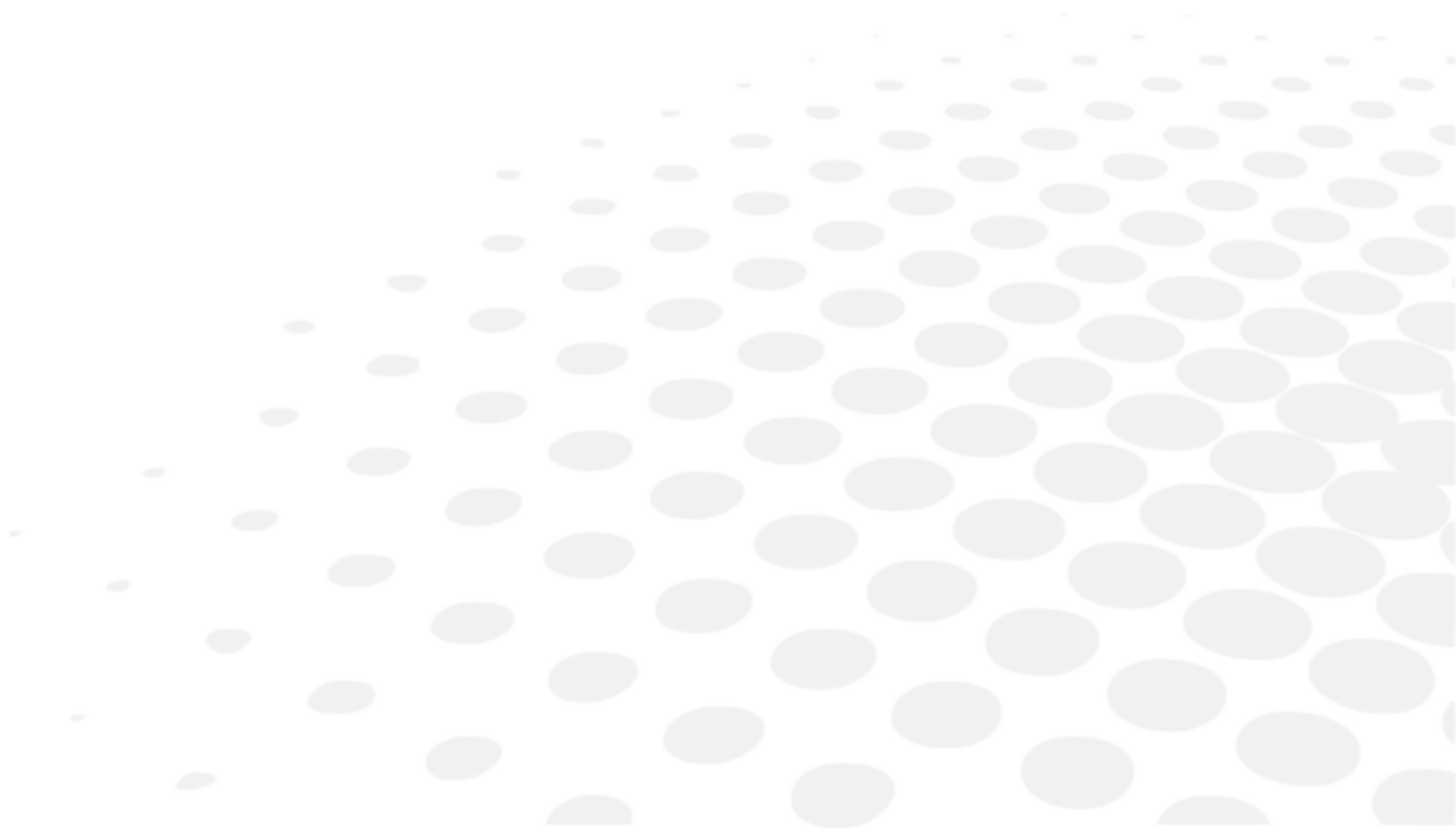

This chapter describes the work environment of the edger and the procedures for edging any type of lens:

- Edger working environment (p.19)
- Perform a Beveling (p.23)
- Beveling for a high-base frame (p.28)
- Produce a step bevel for a high-base frame of a sporting type or a safety frame, (p.35)
- Grooving (p.50)
- Produce a Flat-edge finish (p.55)
- Do a mixed job (p.56)
- Do a drilled job (p.58)
- Perform a Polishing (p.61)
- Perform a Chamfering (p.62)
- Perform a Retouching (p.63)

1. Edger working environment





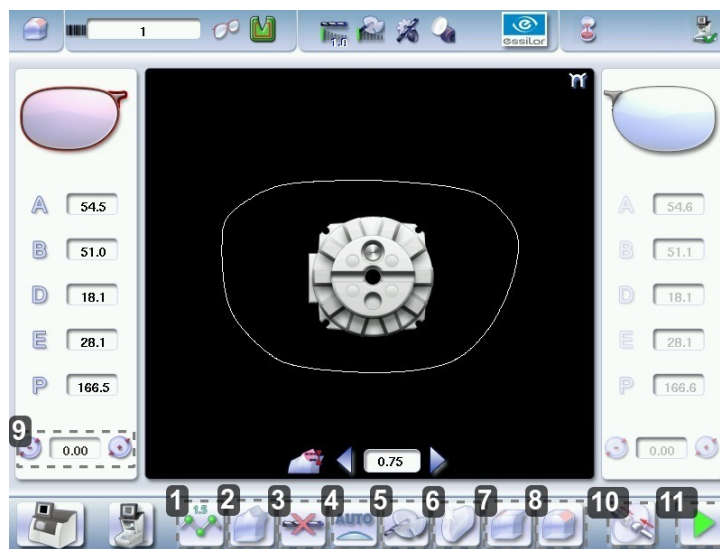

This section describes the edger working environment and the initial stages of the edging of a lens.

- Description of the edging screen (p.19)
- Shape call-up procedure (p.21)
- Putting the lens in place (p.21)

a. Menu screen







1. Lens material

-  Plastic lens - index 1.5 (p.130)
-  Polycarbonate lens
-  Medium or high index plastic lens - index > 1.5
-  Trivex lens™
-  Glass lens
-  Tribrid lens™



The configuration of the edging cycles depends on the type of material. An incorrect choice may result in material damage.

2. Type of finish



-  Bevel

-  High-base bevel
-  Step bevel
-  Groove
-  Flat-edge finish
-  Mixed job



3. Drilling

-  Drilling enabled
-  Drilling disabled



4. Edging mode

-  Automatic mode
The finish parameters are automatically calculated according to the information acquired when tracing the frame and feeling the lens.
-  Customized mode
The finish settings can be fully customized.



5. Type of cycle

-  Milling cycle
This cycle is recommended for lenses with a hydrophobic coating. It is suited to all types of materials except glass lenses. Milling involves a specific feeling cycle: the edger will feel the contour of the shape to be edged twice, then four feeling operations will be required every 90° to define the segments to be cut.
-  2 stars Cycle
For all types of materials. This cycle offers a more sophisticated edging mode than the standard cycle, dedicated to thin lenses or hydrophobic lenses.
-  Standard cycle
For all types of materials.



6. Polishing

-  Polished lens
-  Non-polished lens

7. Front surface chamfering

-  Small chamfer
-  Large chamfer
-  No chamfering

8. Rear surface chamfering

-  Small chamfer
-  Large chamfer
-  No chamfering

9. Size reduction/increase (mm)

10. Manual lens clamping

Press and hold to close the lens clamp shafts manually.

11. Start the edging cycle

The door closing and lens clamping are automatic.



Always browse from left to right: depending on your selection, certain menus will be available while others will not.





Your habits taken into account

The digital system memorises your working habits: as time goes by, the buttons of the functions you use most often will be displayed by default.

b. Calling up a shape

There are 3 ways of calling up the shape you want to edge:

- Calling up the current job:
 - > Press  to display the shape being processed on the tracer.
- Calling up the number of a shape saved on the tracer:
 - > Press  for a few seconds to open the numeric keypad.
 - > You can then call up a shape via the ID allocated to it.
- Job call via a barcode:
 - > Scan the barcode using the barcode reader (optional).

Always lock down your 2 lenses before proceeding with the edging. If a job in the course of modification on the tracer (display of the symbol  beside the reference) is called up on the edger, a warning message is displayed.

> Press  to continue and display the job on the edger. The modifications underway are then ignored.

> Press  to prevent the display of the job and finish the modifications underway on the tracer.



A reminder of the type of posiblock required is displayed on the shape. It is crucial to use the proper accessory to edge the lens. Otherwise, an error message is displayed at the start of the cycle.

c. Lens set-up and feeling

 Prerequisite: the lens must be centered and blocked before placing it in the edger.

1 Check that the posiblock holder and the stop correspond to the posiblock used. Otherwise, you will need to remove them from the lens clamp shafts and replace them with the tools matching the diameter of the posiblock.

- For a 22 mm posiblock

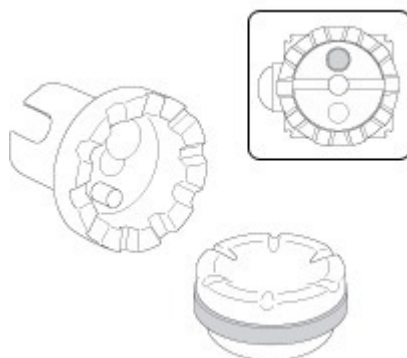

- For an 18 × 14 mm posiblock

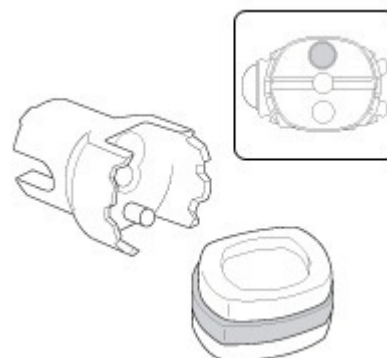

2 Place the lens in the posiblock holder.



Place the metal peg of the posiblock upwards and the positioner downwards: a magnet is used to hold the lens in position on the axis.

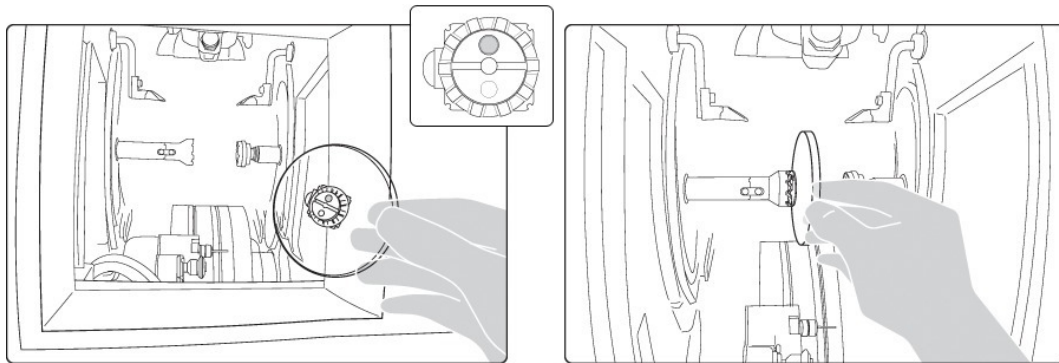

You can clamp the lens manually by pressing . Manual lens clamping is particularly suited to hydrophobic lenses, thick lenses and high-camber lenses, as it ensures that the lens won't come off the pad before clamping.



Make sure you move your hand well away before you start the edging cycle.

3 Press .

- > The door closes then the lens clamping operation starts.
- > The size of the posiblock holder is checked then the feeling cycle starts.



To interrupt the feeling cycle at any time, press .

- > As the lens is felt, its shape appears on screen. The double tracing represents the profile of the front surface of the shape (inner shape) and its rear surface (outer shape).

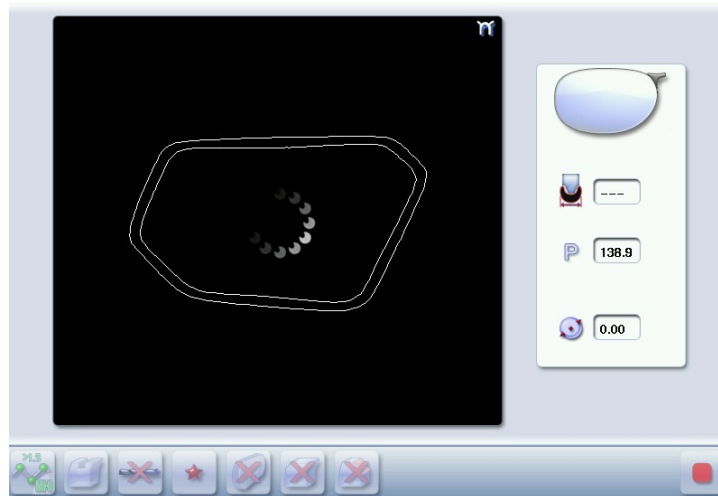

- > In the case of edging mode selection:
 - automatic, you do not have to configure anything, all the data is automatically recovered from the tracer. The lens edging starts automatically after the feeling cycle.
 - customized, the finish parameters can be fully customized.



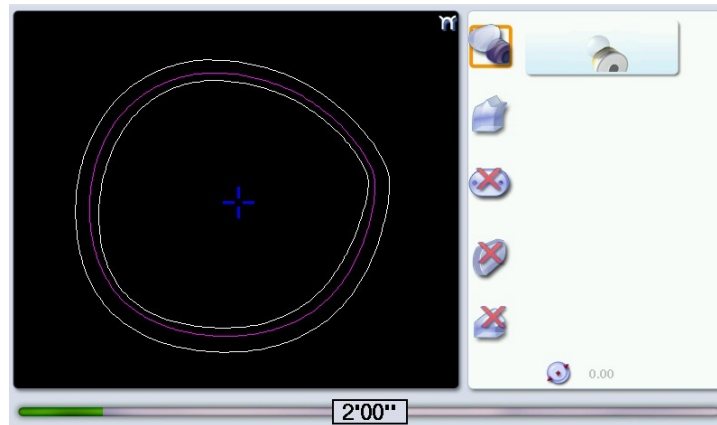

For further information, refer to the section concerning your type of finish.

- > The various stages of the edging of the lens appear on the screen, a progression bar indicates the remaining cycle time.



2. Perform a Beveling

This section describes the procedures for the creation of a bevel:

-  In automatic mode (p.24), you do not have to configure anything. All the data is automatically retrieved from the tracer. The lens edging starts automatically after the feeling cycle.
-  In customized mode (p.26), you can opt for front/rear surface tracking, a distributed bevel, lens curve tracking or frame rim tracking. You can also do the following:
 - a total modification of the bevel curve (p.27)
 - a modification of a certain point of the bevel curve (p.27)
 - a displacement of the bevel curve (p.28)
- You can consult the description of the customized bevel screen. (p.25)



a. Automatic beveling

- 1 Call up the desired shape located on the tracer.
 - > The shape is displayed on the edger work screen.
 - > After the tracing of a rimmed frame:
 - The bevel finish is selected by default.
 - The automatic mode is selected by default.



If you want to produce a bevel less than 0.75mm high, configure the bevel directly on the screen.



- 2 Press  and  to adjust the height of the bevel.



	Height (mm)
By default	0.75
Minimum	0.30
Maximum	0.75

- 3 Select lens material.
- 4 Select the type of cycle.
- 5 Choose whether or not to polish and/or chamfer your lens.



For more information, consult the section [Edging a lens > Perform a polishing \(p.61\)](#) and [Edging a lens > Perform a chamfering \(p.62\)](#).

- 6 Press .
 - > The door closes, the lens is clamped, then the feeling operation starts.
 - > The edging cycle starts.
 - > When the edging cycle is finished, the retouch screen is displayed.

- 7 Press  to release the lens.



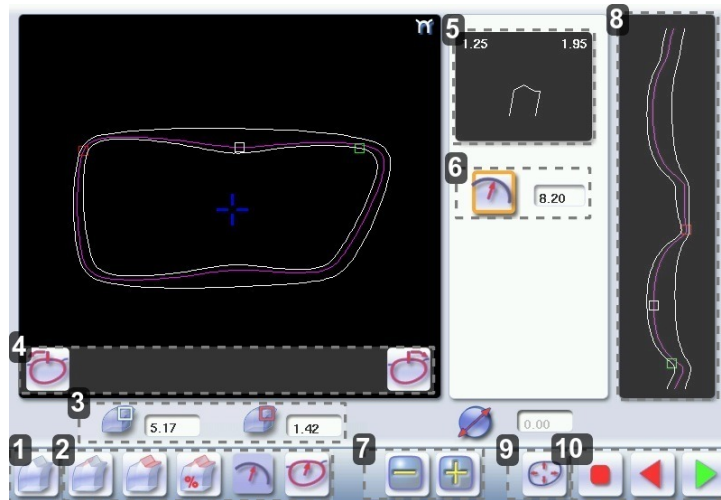

- 8 If necessary, retouch the lens.
Otherwise, start edging the second lens. Select the lens directly on the screen, on the left or right of the work area.
 - > The edging screen for the second lens is displayed. All finishes chosen and modifications made are kept.

b. Legend screen for customized levels





1. Automatic bevel



2. Customized bevels

-  Front surface tracking: the crest of the bevel is positioned at a constant distance from the front surface.
-  Rear surface tracking: the crest of the bevel is positioned at a constant distance from the rear surface.
-  Distributed bevel: the position of the crest of the bevel is proportional to the thickness of the lens, with respect to the front surface.
-  Lens curve tracking: the camber of the bevel is adjustable.
-  Frame rim tracking: the bevel follows the groove in a precise way, according to the data obtained from the frame tracing.

3. Lens thickness

-  Maximum lens thickness - represented by the white square along the shape.
-  Minimum lens thickness - represented by the red square along the shape.

4. Cursor movement

The cursor is represented by the green square along the shape. To move it, select it directly or use the buttons  and .

5. Zoom window

Represents the bevel profile and indicates the distance between the bevel crest and the front and rear surfaces of the lens at the cursor position.

6. Bevel distribution value

Distribution value modifiable for:

- front/rear surface tracking
- a distributed bevel
- lens curve tracking



7. Modify the selected value

Reduce or increase the distribution value.



8. Bevel trajectory

Flat representation of the lens making it possible to assess the distances between the bevel crest and the front & rear surfaces of the lens.

9. Trajectory modification





-  General modification of the bevel curve
-  Modification of the bevel curve at a particular point
-  Displacement of the bevel curve



10. Navigation

-  Stop the cycle
-  Return to the main edging screen
-  Start the edging cycle

c. Customized beveling





The use of the customized bevel depends on 2 parameters: the frame and the lens. Before starting your job, identify the major constraint.

BEVEL	FRAME	LENS	ADVANTAGES
	Classic	Lens for which the front surface base is approximately equal to the frame base.	Makes it possible to do an aesthetically pleasing job. The lens material does not protrude beyond the front of the frame.
	Classic	Lenticular lens ^(p.130) , Executive lens ^(p.130)	Makes it possible to do a job with specific lenses.
	Classic	Thin lens	Makes it possible to balance out the bevel when thin lenses are used.
	Flat base High base	Thin lens for which the front surface base is approximately equal to the frame base.	Makes it possible to retrieve the frame base in a pattern tracing (base = 0).
	Specific groove (groove with meniscus ^(p.130))	Thin lens for which the base is approximately equal to the meniscus of the groove.	Compliance with original shape. Job using a specific frame.

- 1 Call the desired shape located on the tracer.
 - > The shape is displayed on the edger work screen.
 - > After the tracing of a rimmed frame:
 - The bevel finish is selected by default.
 - The automatic mode is selected by default.
- 2 Select lens material.
- 3 Change the edging mode. To do this, press  to select the customized mode .
- 4 Select the type of cycle.
- 5 Choose whether or not to polish and/or chamfer your lens.



For more information, refer to the following section Edging > Polishing (p.61) and Edging > Chamfering (p.62).

- 6 Press .
 - > The door closes, the lens is clamped and then felt.
 - > The customized bevel finish screen is displayed.
- 7 Select the type of customized bevel you want to do.
 -  To avoid reproducing defects when tracking a frame rim, check that the frame groove is in perfect condition and that the hinges are properly closed. All groove imperfections will be reproduced.
- 8 Press  and  to adjust the distribution value if required.
- 9 Press .
 - > The edging cycle starts.

> When the edging cycle is finished, the retouch screen is displayed.

10 Press  to release the lens.

11 If necessary, retouch the lens.

Otherwise, start edging the second lens. Select the lens directly on screen, on the left or right of the work area.

> The edging screen for the second lens is displayed. All finishes chosen and the modifications made are kept.

d. Modifying the bevel curve



Once you have configured the desired type of customized bevel, you can complete your customization by moving the bevel curve towards the front or rear surface of the lens so it takes on its shape.

1 Press  in the customized bevel finish screen.

> You will access the trajectory modification screen.

2 Press  to select the general modification of the bevel curve.

3 Use the buttons  and  to move the bevel curve:

- Press  to move the curve towards the front surface of the lens.
- Press  to move the curve towards the rear surface of the lens.



The curve cannot be moved more than the minimum distance between the front and rear surfaces observed on the bevel before the modification.

> The position of the bevel as well as the distances between the crest of the bevel and the front and rear surfaces of the lens are displayed in the zoom window at the position of the cursor.

4 Press .

> The edging cycle starts.

> When the edging cycle is finished, the retouch screen is displayed.

5 Press  to release the lens.

6 If necessary, retouch the lens.

Otherwise, start edging the second lens. Select the lens directly on screen, on the left or right of the work area.

> The edging screen for the second lens is displayed. All finishes chosen and the modifications made are kept.

e. Modifying the bevel curve at a particular point



Once you have configured the desired type of customized bevel, you can complete your customization by partially moving the bevel curve towards the front or rear surface of the lens so it takes on its shape.



1 Press  in the customized bevel finish screen.

> You will access the trajectory modification screen.

2 Press  to select the bevel curve modification at a particular point.

3 Using the cursor, select the point on the curve that you want to move or click directly on the position of the shape you want to modify.

4 Use the buttons  and  to move the selected point on the curve:

- Press  to move it towards the front surface of the lens.
- Press  to move it towards the rear surface of the lens.



The curve cannot be moved more than the minimum distance between the front and rear surfaces observed on the bevel before the modification.

- > The position of the bevel as well as the distances between the crest of the bevel and the front and rear surfaces of the lens are displayed in the zoom window at the position of the cursor.

5 Press .



Press  to go back to the customized bevel finish screen.

- > For the second lens, the customized bevel icon is pre-selected and the trajectory modification icon is displayed.

f. Displacing the bevel curve



The displacement of the bevel curve makes it possible to move the bevel without modifying its curve.

1 Press  in the customized bevel finish screen.

- > You will access the trajectory modification screen.

2 Press  to select the displacement of the bevel curve.

3 Use the buttons  and  to displace the bevel curve:

- Press  to displace it towards the front surface of the lens.
- Press  to displace it towards the rear surface of the lens.

- > The position of the bevel as well as the distances between the crest of the bevel and the front and rear surfaces of the lens are displayed in the zoom window at the position of the cursor.

4 Press .

- > The edging cycle starts.
- > When the edging cycle is finished, the retouch screen is displayed.

5 Press  to release the lens.

6 If necessary, retouch the lens.

Otherwise, start edging the second lens. Select the lens directly on screen, on the left or right of the work area.

- > The edging screen for the second lens is displayed. All finishes chosen and the modifications made are kept.

3. High-base beveling

This section describes the procedures for the creation of a high-base bevel:

- Description of the high-base bevel screens, (p.29)
- Produce a high-base bevel in “automatic trajectory” mode or “front surface tracking” mode. (p.31)

The use of the high-base bevel depends on two parameters: the frame and the lens.

- Concerning the lens, the main constraint is the thickness of the nasal and temporal edges.
- Concerning the frame, the crucial elements are the bridge and shape of the groove. The hinge is an additional factor in the case of a metal frame, the arms for a plastic frame.

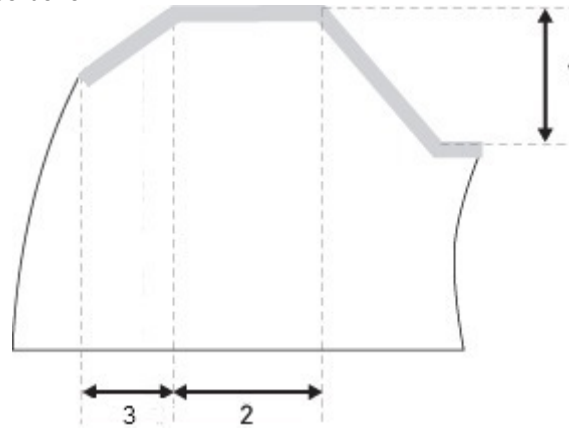

For this job, the lens base must always match the frame base perfectly. Too great a difference between the two could be detrimental to the quality of your job.

Cross-sectional view of a high-base bevel

- 1: Shelf bevel value
- 2: Width of the flat side of the bevel
- 3: Front surface tracking value

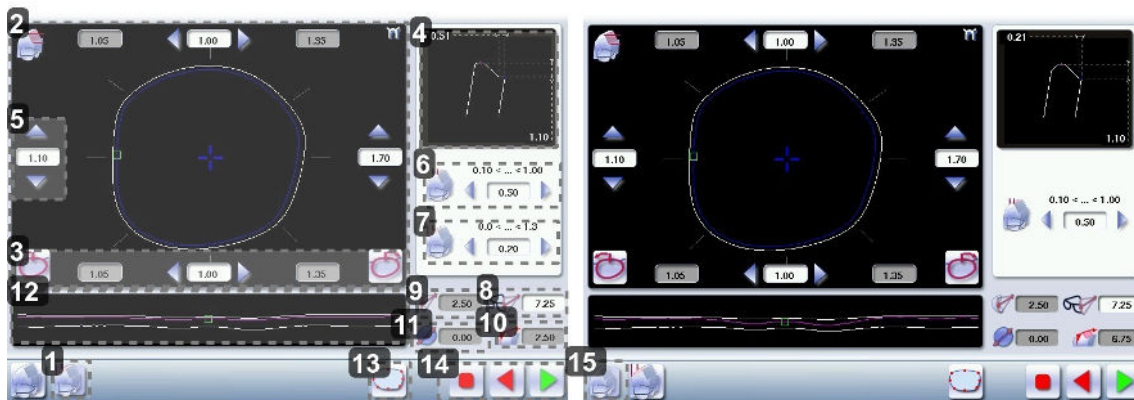
a. Captioned screens

1. High-base bevel "front surface tracking" screen

2. Work area



Image of the shape to be edged:

Frame shape at bottom of groove

Bevel trajectory on rear surface

Bevel trajectory on rear surface if the lens used is too thin to achieve the desired finish.

3. Cursor movement

The cursor is represented by the square located along the shape. To move it, select it directly or use the  and  buttons.

4. Zoom window

Represents the bevel profile at the position of the cursor.

5. Shelf bevel value (8 or 4 values)

- Nasal (the value must be between 0.25 and 2 mm)
- Mid-nasal (the value must be between 0.25 and 2 mm)
- Upper (the value must be between 0.25 and 2 mm)
- Mid-Upper (the value must be between 0.25 and 2 mm)
- Temporal (the value must be between 0.25 and 2 mm)
- Mid-temporal (the value must be between 0.25 and 2 mm)
- Lower (the value must be between 0.25 and 2 mm)
- Mid-lower (the value must be between 0.25 and 2 mm)

6. *Width of the flat side of the bevel*

The value of the flat side of the bevel must be between 0.1 mm and 1 mm.

7. *Front surface tracking value*

The front surface tracking value must be between 0 mm and 1.3 mm. This value is definable only in the “front surface tracking” screen.

8. *Frame base*

9. *Lens base*

10. *Bevel Base_Range of values of the lens base necessary for the frame*

If the lens base used is out of range: the range values are shown in red.

11. *Reminder of size reduction/increase applied to lens diameter*

12. *Window showing the bevel trajectory on the lens section*

Centre of the flat side of the bevel



Front surface/rear surface of lens

13. *Number of shelf bevel values*

 Transition from 4 to 8 shelf bevel values.

 Transition from 8 to 4 shelf bevel values.

14. *Navigation*

-  Stop the cycle
-  Back to the main edging screen
-  Start the edging cycle

15. *High-base bevel screen “automatic trajectory”*

In this screen, the trajectory on the lens section cannot be configured: it is calculated automatically. This calculation harmonises as best as possible, the lens base, the base of the frame and the shape.

b. High-base beveling

1 Call up the desired shape located on the tracer.

- > The shape is displayed on the edger work screen.
- > After the tracing of a high-base frame:
 - The high-base finish is selected by default.
 - The customized mode is selected by default.



In high-base finish, you cannot polish your bevel. However, the high-base wheel has been designed to provide an equivalent finish on polycarbonate lenses.

2 Select lens material.



You cannot do a high-base bevel on Trivex™ and glass lenses.

3 Select the type of cycle.

4 Choose to create or not to create a thin or a high chamfer on the rear surface of the lens.



For more information, consult the section Edging a lens > Perform a polishing (p.61) and Edging a lens > Perform a chamfering (p.62).

5 Press .

- > The door closes, the lens is clamped and then felt.
- > The high-base bevel finish screen “automatic trajectory” is displayed by default.

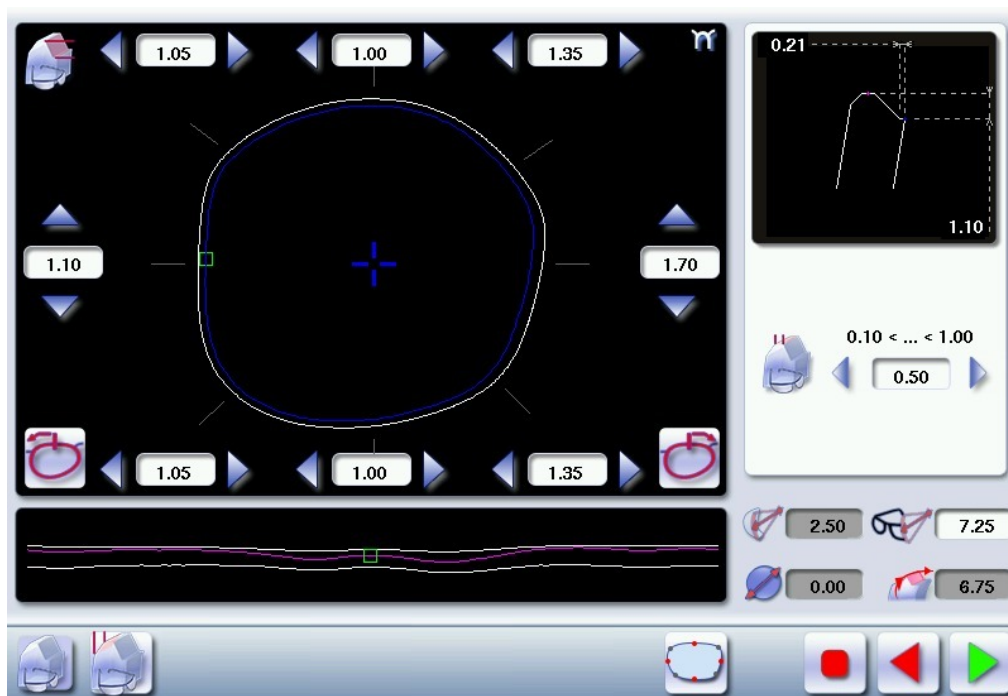

By default, the edger shows the values corresponding to the frame material (metal or plastic). Check and modify these values according to the thickness of your lens and your frame.

You can:



- produce a high-base bevel in “automatic trajectory” mode, (p.32)
- produce a high-base bevel in “front surface tracking” mode. (p.34)

High-base bevel in “automatic trajectory” mode

1 Press  to select the bevel in “automatic trajectory” mode.

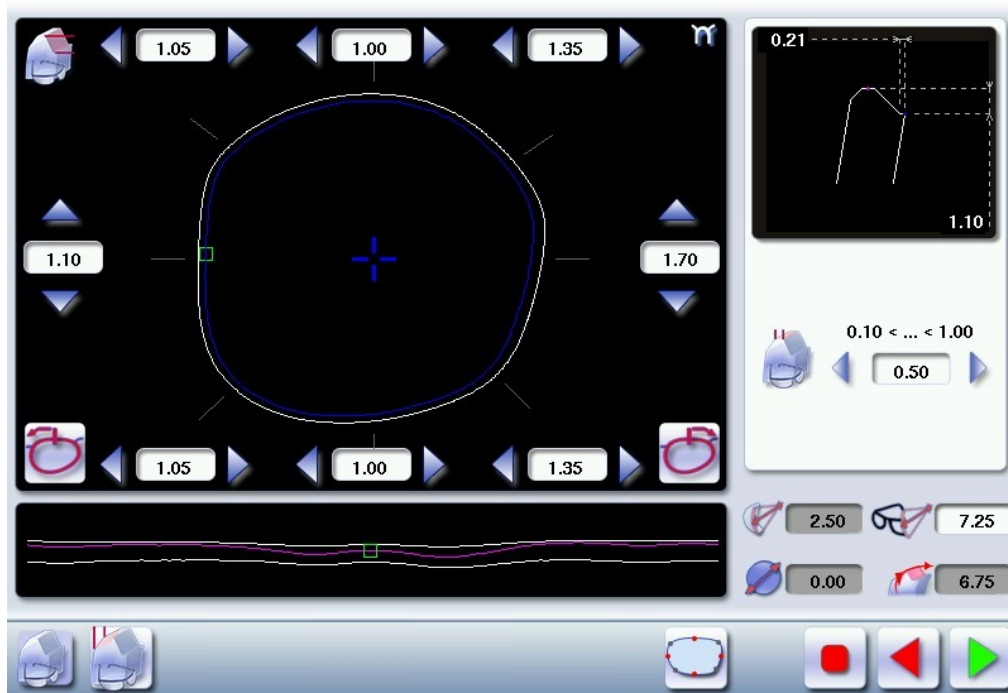

> The following screen will appear:

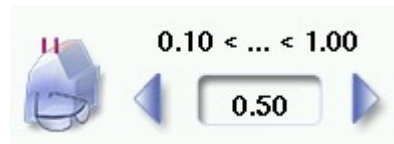

2 Press the buttons  and  on the right of your screen to modify the width of the flat side of the bevel.



> The result can be viewed in the zoom window.

3 Press the   and  buttons to modify the shelf bevel value at each point of the shape in each area:

- Temporal
- Mid-temporal
- Nasal
- Mid-nasal
- Upper
- Mid-upper
- Lower
- Mid-lower

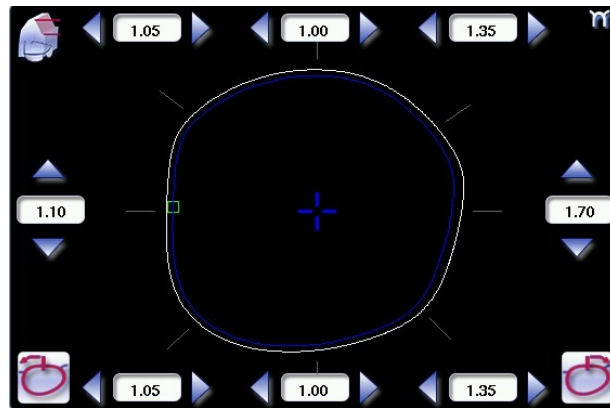

Move the cursor along the shape to see the bevel profile in the zoom window.

- > The edger calculates the shelf bevel value to be applied between each of the four points in each area.
- > The bevel trajectory on the rear surface is modified in the work screen. The result can be viewed in the zoom window.

4 Press .

- > The edging cycle starts.
- > When the edging cycle is finished, the retouch screen is displayed.

5 Press  to release the lens.

6 If necessary, retouch the lens.

Otherwise, start edging the second lens. Select the lens directly on the screen, on the left or right of the work area.



- > The edging screen for the second lens is displayed. All finishes chosen and modifications made are kept.

High-base bevel in “front surface tracking” mode

1 Press  to select the bevel in “front surface tracking” mode.

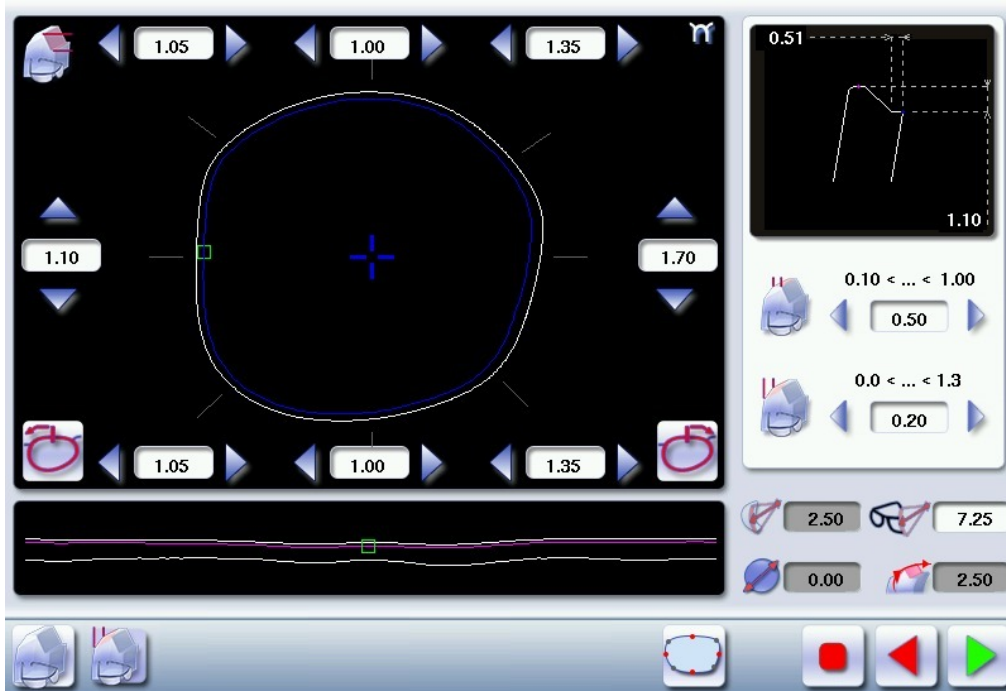



> The following screen will appear:

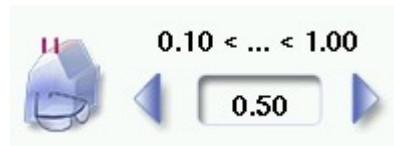

2 Press the buttons  and  on the right of your screen to modify the width of the flat side of the bevel.



> The result can be viewed in the zoom window.

3 Press the   and   buttons to modify the shelf bevel value at each point of the shape in each area:

- Temporal
- Mid-temporal
- Upper
- Mid-upper
- Nasal
- Mid-nasal
- Lower
- Mid-lower

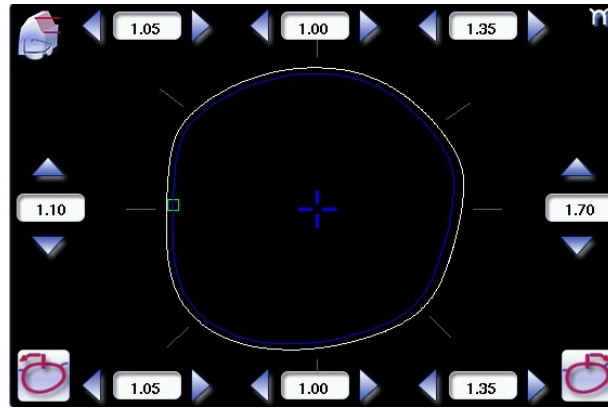

Move the cursor along the shape to see the bevel profile in the zoom window.

- > The edger calculates the shelf bevel value to be applied between each of the four points in each area.
- > The bevel trajectory on the rear surface is modified in the work screen. The result can be viewed in the zoom window.

4 Press the ◀ and ▶ buttons on the right of your screen to modify the front surface tracking value.



- > The result can be viewed in the zoom window and in the window showing the bevel trajectory on the lens section.

5 Press ▶.

- > The edging cycle starts.
- > When the edging cycle is finished, the retouch screen is displayed.

6 Press 🛑 to release the lens.

7 If necessary, retouch the lens.

Otherwise, start edging the second lens. Select the lens directly on the screen, on the left or right of the work area.

- > The edging screen for the second lens is displayed. All finishes chosen and modifications made are kept.

4. Perform a Step beveling (option)



The step bevel finish is active and available only if the tool is installed on the GMD module.



The V 9.0 memory version is essential.



Following the first installation of the Step bevel tool, we recommend that you adjust the function.

🔧 Prerequisite:

- Necessary memory version: V 9.0.0
- Step Bevel kit:
 - 🛠️ Step bevel wheel with its set-up accessory
 - 🛠️ Tool for disassembling the high-base wheel and the chamfering wheel.

-  Adjustment lens

This section describes:

- the installation procedure for the step bevel tool
- the procedures relating to the creation of a Step bevel:
 - description of the Step bevel screens
 - perform a Step bevel in “automatic trajectory” mode or “front surface tracking” mode.

The use of Step bevel is determined by two settings: frame and lens.

- Concerning the lens, the main constraint is the thickness of the nasal and temporal edges.
- Concerning the frame, the crucial elements are the bridge and shape of the groove. The hinge is an additional factor in the case of a metal frame, the arms for a plastic frame.



For this job, the lens base must always match the frame base perfectly. Too great a difference between the two could be detrimental to the quality of your job.

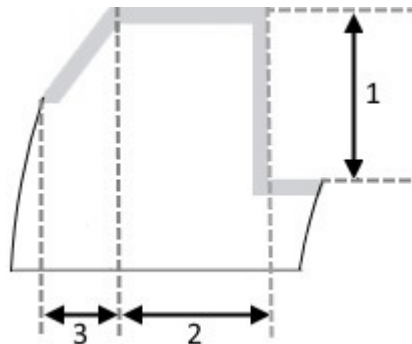

Cross-section of a step bevel



- 1: Value of shelf bevel of rear surface
- 2: Width of the flat side of the bevel
3. Front surface tracking value

a. Mounting of the step level tool

1 You will need the following:

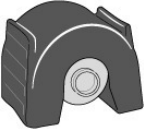
	Allen key
	Open-ended spanner
	"Wheel" disassembly accessory
	Step wheel in its mounting accessory

2 From the working screen of your edger, press  (tool wear indicator) for several seconds to access the screen for tool changes.

> The following screen will appear:



3 Press  to select the step level wheel: CX3831.



- 4 Press  to confirm the tool.
- > The GMD module moves to facilitate the operation.
 - > The following message appears:



- 5 Position the disassembly accessory on the high-base wheel and the chamfering wheel.

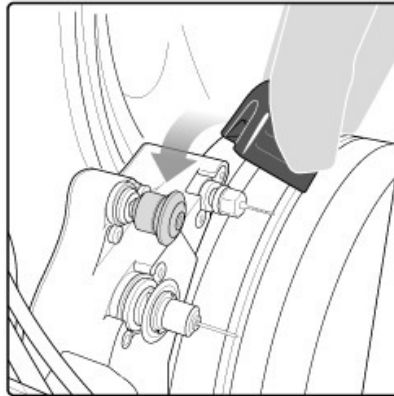

- 6 Position the open-end wrench behind the high-base wheel to hold the spindle, and insert the offset wrench in the screw at the centre of chamfering wheel.

Hold the spanner and use the Allen key to unscrew (downwards) the chamfering wheel .

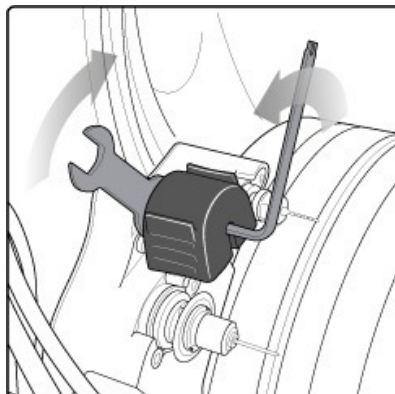

- 7 Remove the disassembly tool, the high-base wheel and the chamfering wheel is disassembled.

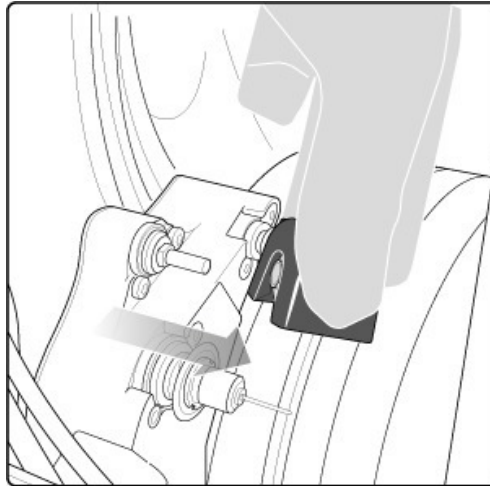

- 8 Position the step bevel wheel with its mounting accessory on the axle.

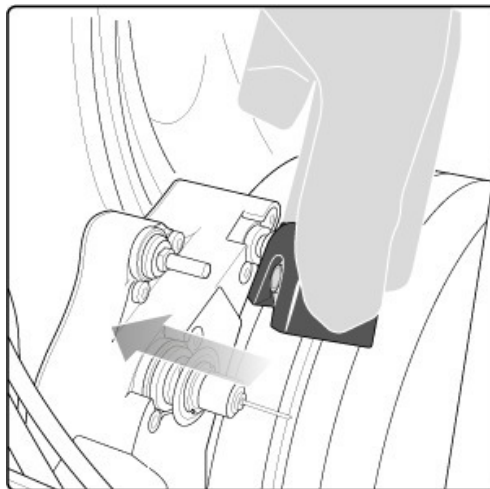

- 9 Hold the open-end wrench and screw (upwards) the step bevel wheel using the offset wrench.

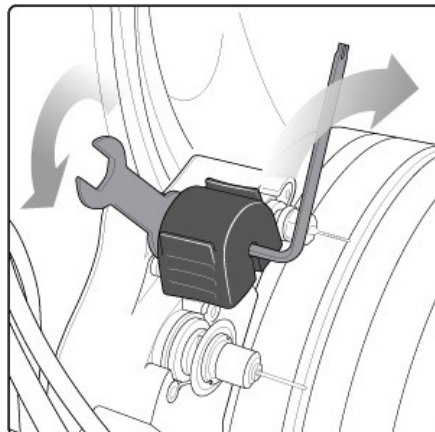

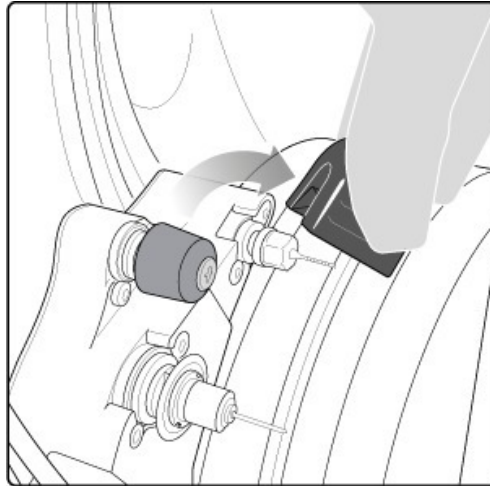

Ensure that the tool is correctly fixed onto the axle using the keys.

- 10 Remove the mounting tool.

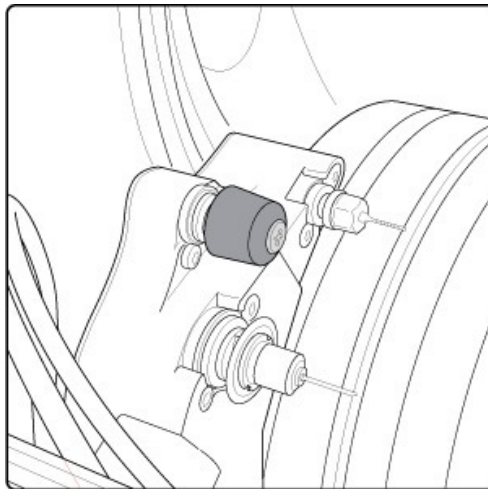

> The wheel is installed.



11 Press  to confirm the tool change, then  to exit the menu.

b. Captioned screens

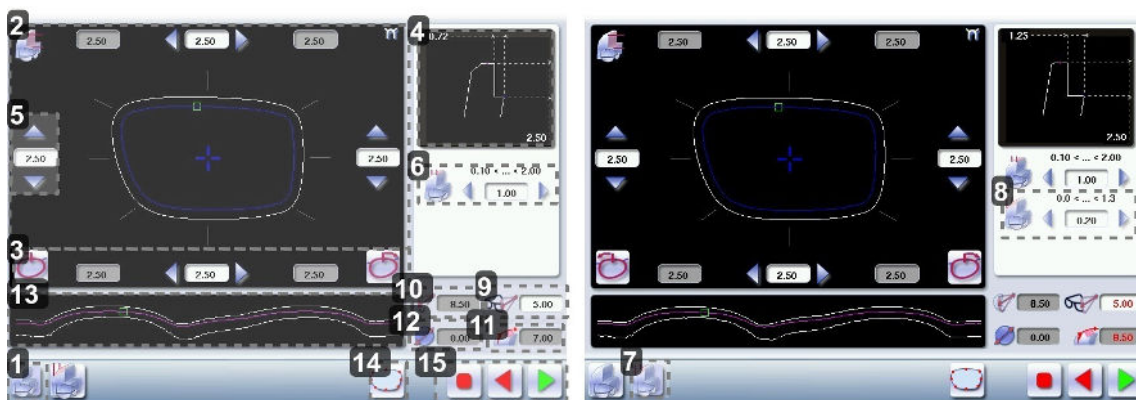

1. Automatic trajectory step bevel screen.

In this screen, the trajectory on the lens section cannot be configured: it is calculated automatically. This calculation harmonises as best as possible, the lens base, the base of the frame and the shape.

2. Work area



Image of the shape to be edged:

Frame shape at bottom of groove

 Bevel trajectory on rear surface

 Bevel trajectory on rear surface if the lens used is too fine to achieve the desired finish.

3. Cursor movement

The cursor is represented by the square located along the shape. To move it, select it directly or use the  and  buttons.

4. Zoom window

Represents the bevel profile at the position of the cursor.

5. Shelf bevel value (8 or 4 values)

- Nasal (the value must be between 0.25 and 3 mm)
- Mid-nasal (the value must be between 0.25 and 3 mm)
- Upper (the value must be between 0.25 and 3 mm)
- Mid-upper (the value must be between 0.25 with 3 mm)
- Temporal (the value must be between 0.25 and 3 mm)
- Mid-temporal (the value must be between 0.25 and 3 mm)
- Lower (the value must be between 0.25 and 3 mm)
- Mid-lower (the value must be between 0.25 and 3 mm)

6. Width of the flat side of the bevel

The value of the flat side of the bevel must be between 0.1 mm and 2 mm.

7. Front surface tracking step bevel screen

8. Front surface tracking value

The value of front surface tracking must be between 0 mm and 1.3 mm. This value is definable only in the “front surface tracking” screen.

9. Frame base

10. Lens base

11. Bevel Base_Range of values of the lens base necessary for the frame

If the lens base used is out of range: the range values are shown in red.

12. Reminder of size reduction/increase applied to lens diameter

13. Window showing the bevel trajectory on the lens section

 Centre of the flat side of the bevel



Front surface/rear surface of lens

14. Number of shelf bevel values

 Transition from 4 to 8 shelf bevel values.

 Transition from 8 to 4 shelf bevel values.

15. Navigation

-  Stop the cycle
-  Return to the main edging screen
-  Start the edging cycle

c. Adjusting the Step bevel finish



Make sure that the step bevel wheel is installed.

It is recommended that you check the function's adjustment before carrying out the edging of the first job or after the set up of a new tool.

 Prerequisite:

You will need:

- the adjustment lens:



- the barcode below:



- a slide caliper:



The procedure below is **specific**, it applies only to the adjustment of the function when the kit is received

Quick adjustment procedure for the step bevel function once the kit is received

- 1 Position the posiblock with its sticker in the centre of the adjustment lens.
- 2 Place the lens in the posiblock holder.
- 3 From the work screen: scan the barcode below:



> The following screen will appear:

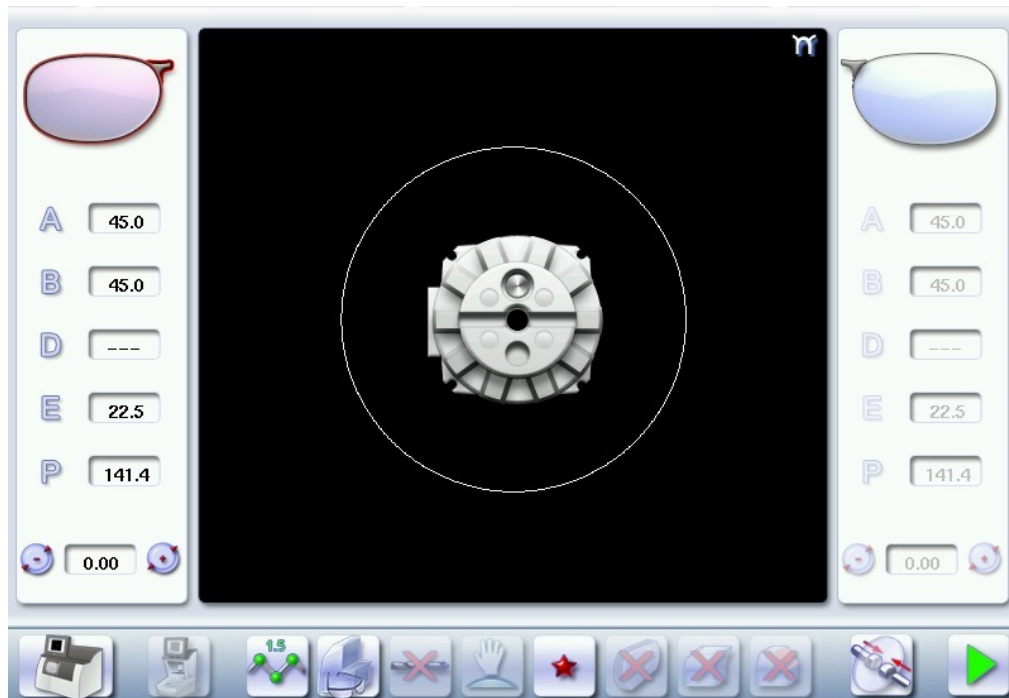

- 4 Press .

> The door closes, the lens is clamped and then felt.

> The following screen will appear:

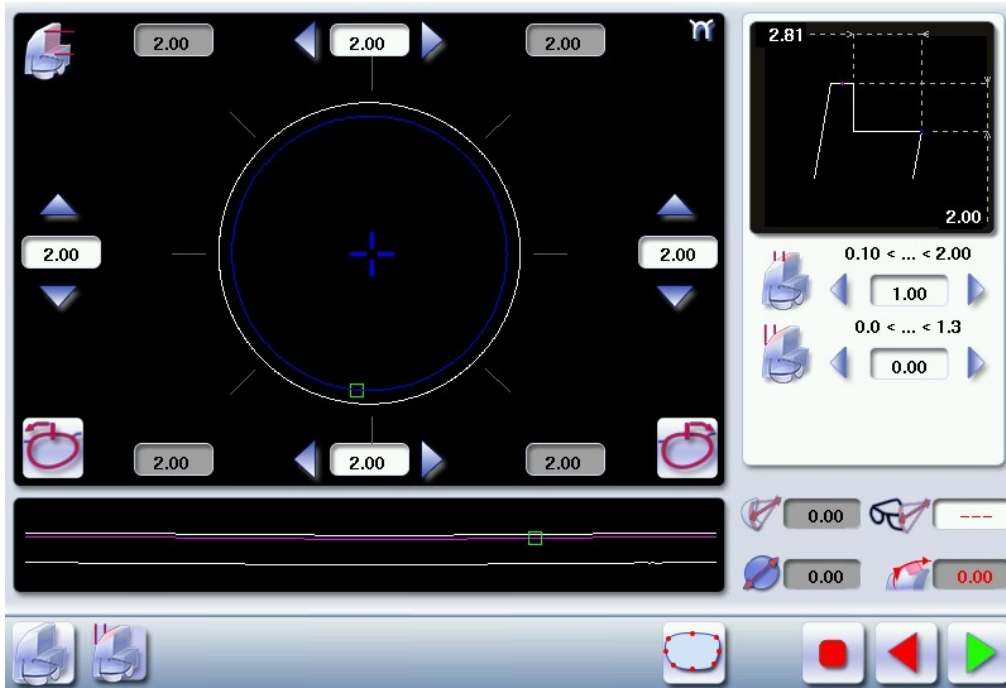

The job is already parameterised.

- 5 Press to start the edging cycle.
- 6 Press to release the lens once the cycle is finished.
- 7 Select > > to access the adjustment screen.

> The following screen will appear:



1. *High base bevel (non accessible)*

For more information, consult the section *Setting the edger > Adjusting the precision of the edger > Adjusting the high-base bevel and the step bevel (p.74)*

2. *Step bevel*

3. *Fields to be completed*

1. Press the value to be modified.
 - > The numeric keypad is displayed.
2. Enter the corrective measure.
 - Negative value: the thickness value of the step will be smaller
 - Positive value: the thickness value of the step will be larger
3. Press  to confirm.

8 Measure with a slide caliper the thickness of the side of the step.

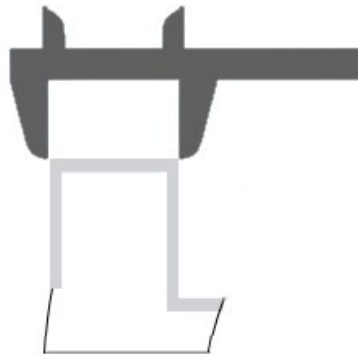

9 Make the necessary changes in the column  for each material.

Expected value	Value obtained	Correction to be made
1 mm	0.8 mm	+0.2
	1.2 mm	-0.2

10 Once the modification is made, recopy the corrective measure in all the lines of the column, press  to return to the work screen.

11 Perform a retouch by carrying out a size reduction of 5mm.

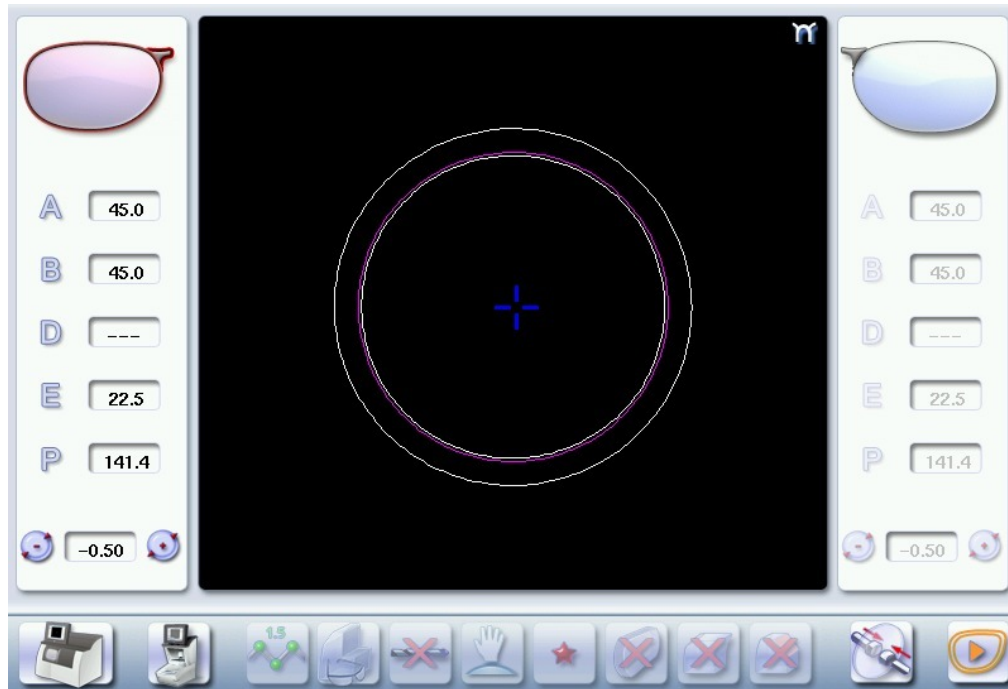

12 Press  to start the cycle.

13 Again measure the thickness of the side of the step.



- > The thickness of the Step bevel must be 1 mm.
- > The adjustment is finished.



If the thickness of the Step bevel is not 1 mm, contact your customer support.

d. Perform a Step bevel

1 Call up the desired shape located on the tracer.

> The shape is displayed on the edger work screen.

> After the tracing of a high-base frame:

- The step finish is selected by default.
- The customized mode is selected by default.



In the step finish, you cannot polish your bevel. Nevertheless, the step wheel was designed to create a finish that is equivalent to polycarbonate lenses.

2 Press  to select the Step bevel.



The button appears grayed if the step bevel wheel was not mounted beforehand: .

3 Select lens material.



You cannot perform a bevel step on the Trivex lenses™ and glass lenses.

4 Select the type of cycle.

5 Press .

> The door closes, the lens is clamped and then felt.

> The “automatic trajectory” step finish screen is displayed by default.



By default, the edger shows the values corresponding to the frame material (metal or plastic). Check and modify these values according to the thickness of your lens and your frame.

You can:



- perform a step bevel in “automatic trajectory” mode (p.47),
In this mode, the bevel trajectory follows the base of the frame as closely as possible.
- perform a step bevel in “front surface tracking” mode (p.49).
In this mode, the trajectory of bevel follows the front surface lens base as closely as possible.

Step bevel in "automatic trajectory" mode

1 Press  to select the bevel in "automatic trajectory" mode

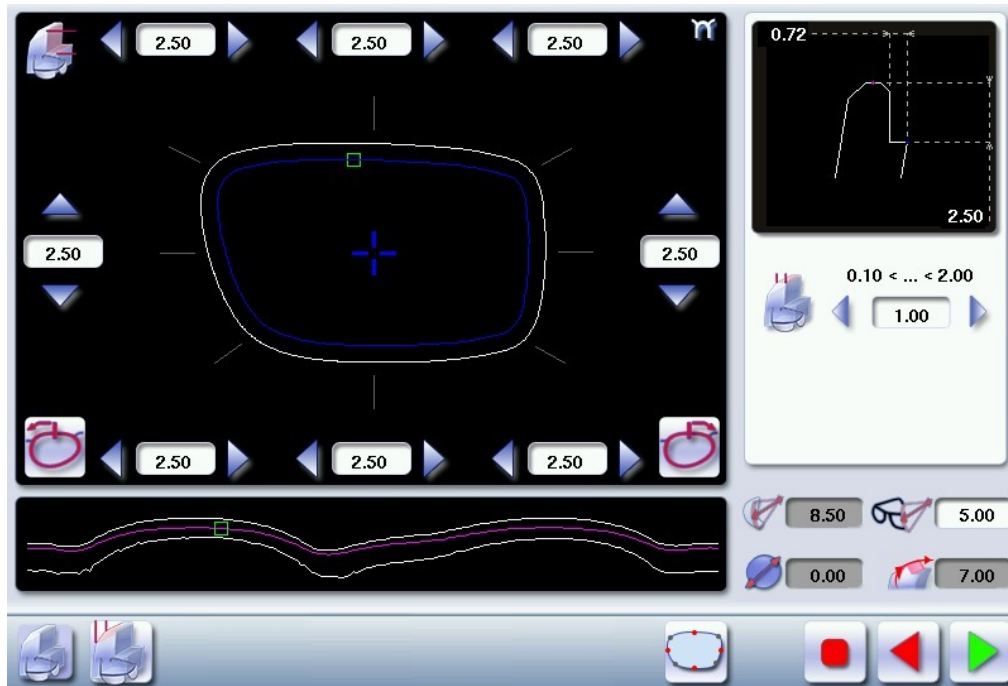
> The following screen will appear:





2 Press the buttons  and  on the right of your screen to modify the width of the flat side of the bevel.

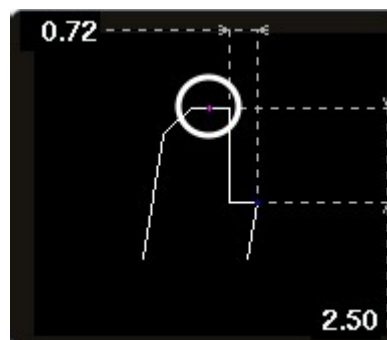

> The result can be viewed in the zoom window.



3 Press on the buttons   and  to modify the shelf bevel value in each point of the shape in each of the areas, 4 or 8 areas:

- Temporal
- Mid-temporal
- Upper
- Mid-upper
- Nasal
- Mid-nasal
- Lower
- Mid-lower

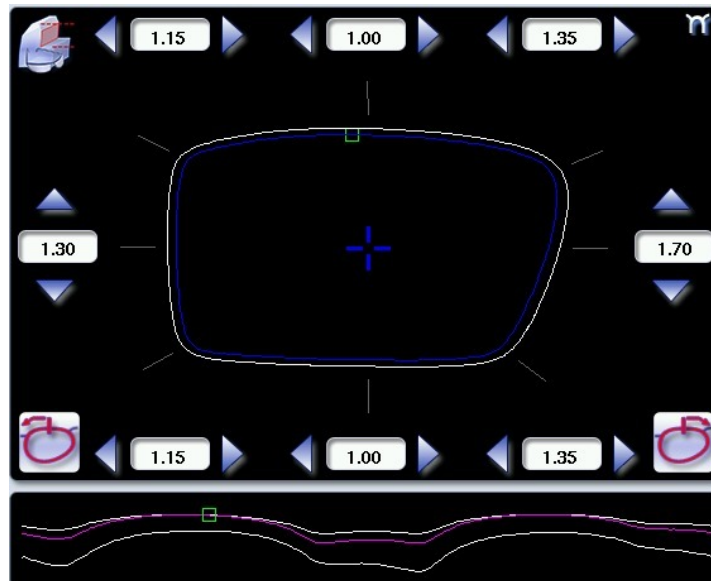

Move the cursor along the shape to see the bevel profile in the zoom window.

- > The edger calculates the shelf bevel value to be applied between each of the four or eight points of each area.
- > The bevel trajectory on the rear surface is modified in the work screen. The result can be viewed in the zoom window.

4 Press .

- > The edging cycle starts.
- > When the edging cycle is finished, the retouch screen is displayed.

5 Press  to release the lens.

6 If necessary, retouch the lens.

Otherwise, start edging the second lens. Select the lens directly on the screen, on the left or right of the work area.



- > The edging screen for the second lens is displayed. All finishes chosen and modifications made are kept.

High-base level in “front surface tracking” mode

1 Press  to select the bevel in “front surface tracking” mode.

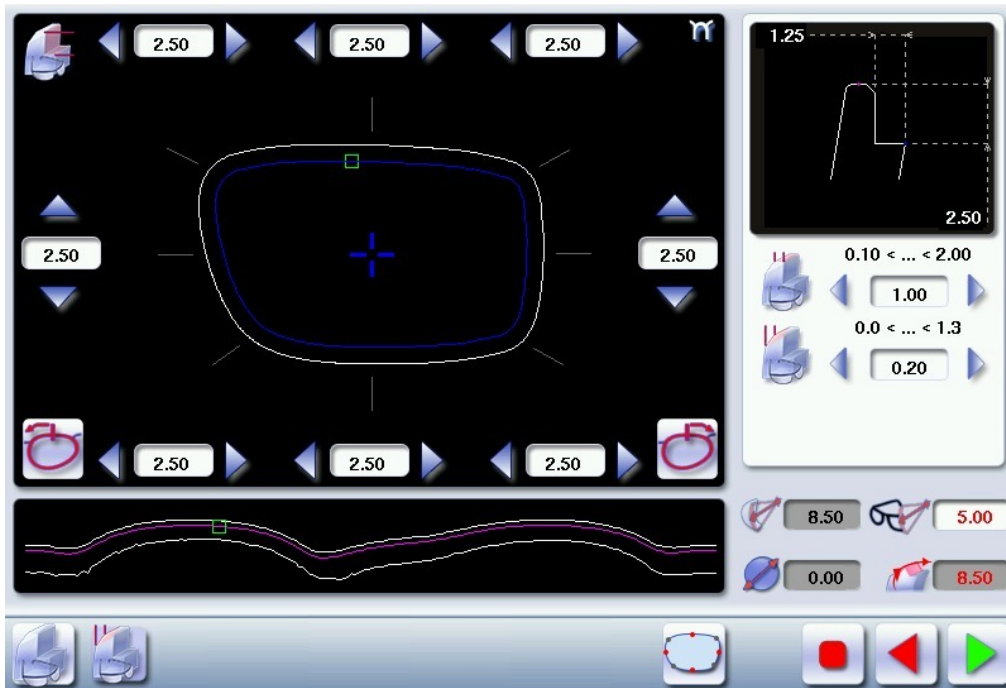
> The following screen will appear:



2 Press the   and  buttons to modify the shelf bevel value at each point of the shape in each area:

- Temporal
- Mid-temporal
- Upper
- Mid-upper
- Nasal
- Mid-nasal
- Lower
- Mid-lower

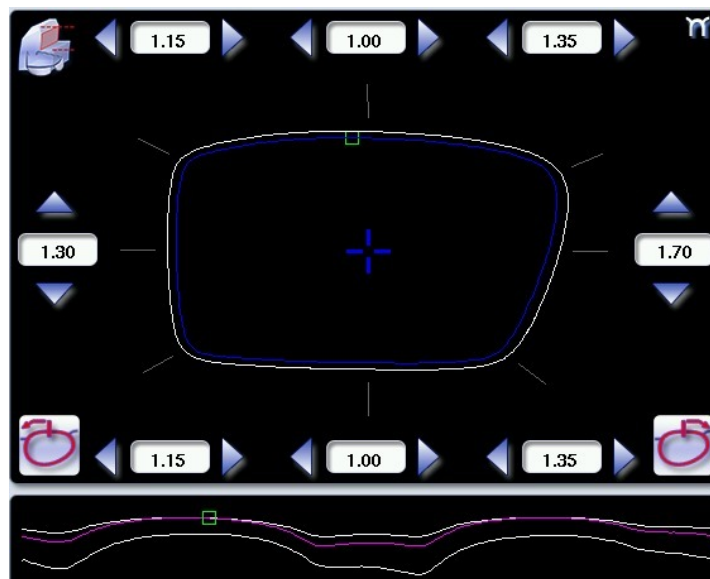



Move the cursor along the shape to see the bevel profile in the zoom window.

- > The edger calculates the shelf bevel value to be applied between each of the four or eight points of each area.
- > The bevel trajectory on the rear surface is modified in the work screen. The result can be viewed in the zoom window.

3 Press the buttons ◀ and ▶ on the right of your screen to modify the width of the flat side of the bevel.

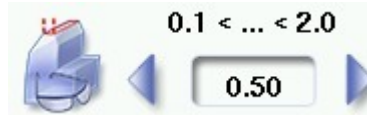

- > The result can be viewed in the zoom window.

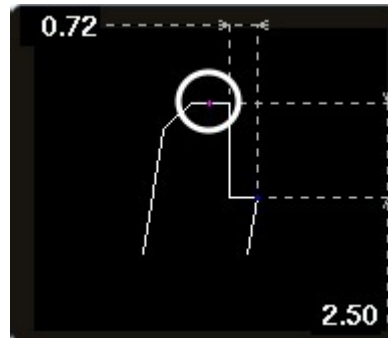

4 Press the ◀ and ▶ buttons on the right of your screen to modify the front surface tracking value.

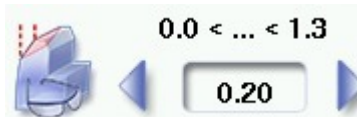

- > The result can be viewed in the zoom window and in the window showing the bevel trajectory on the lens section.

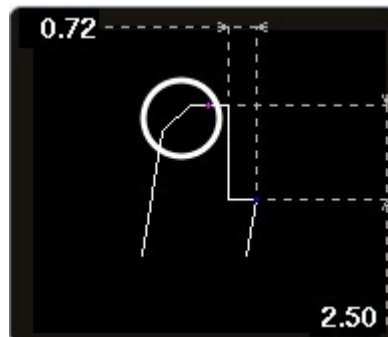

5 Press ▶.

- > The edging cycle starts.
- > When the edging cycle is finished, the retouch screen is displayed.

6 Press  to release the lens.



7 If necessary, retouch the lens.

Otherwise, start edging the second lens. Select the lens directly on the screen, on the left or right of the work area.

- > The edging screen for the second lens is displayed. All finishes chosen and modifications made are kept.

5. Grooving

This section describes the procedures for the creation of a groove:

-  In automatic mode (p.51), you do not have to configure anything. All the data is automatically retrieved from the tracer. The lens edging starts automatically after the feeling cycle.
-  In customized mode (p.53), you can perform a front/rear surface tracking, a distributed groove or a lens curve tracking. You can also do the following:
 - a total modification of the groove curve (p.54)
 - a modification of a certain point of the groove curve (p.54)
 - a displacement of the curve of groove (p.55)
- You can consult the description of the screen of the custom groove (p.51).



- In certain cases, the lens base or thickness makes grooving impossible.
- > An error message is displayed.
 - > The white central line becomes red on the entire contour of the lens.



a. Automatic grooving

- 1 Call up the desired shape located on the tracer.
 - > The shape is displayed on the edger work screen.
 - > After tracing a pattern, demo lens or re-cut lens, without any drilling settings:
 - the groove finish is selected by default.
 - the automatic mode is selected by default.



If you wish to produce a groove the depth and the width of which are less than 0.60 mm: Directly define the groove in the screen.



- 2 Press  and  to regulate the depth and the width of the groove





	Depth (mm)	Width (mm)
By default	0.60	0.60
Minimum	0.20	0.60
Maximum	1.20	1.20

- 3 Select lens material.
- 4 Select the type of cycle.
- 5 Choose whether or not to polish and/or chamfer your lens.



For more information, consult the section Edging a lens > Perform a polishing (p.61) and Edging a lens > Perform a chamfering (p.62).

- 6 Press .
 - > The door closes, the lens is clamped and then felt.
 - > The edging cycle starts.
 - > When the edging cycle is finished, the retouch screen is displayed.
- 7 Press  to release the lens.
- 8 If necessary, retouch the lens.

Otherwise, start edging the second lens. Select the lens directly on the screen, on the left or right of the work area.



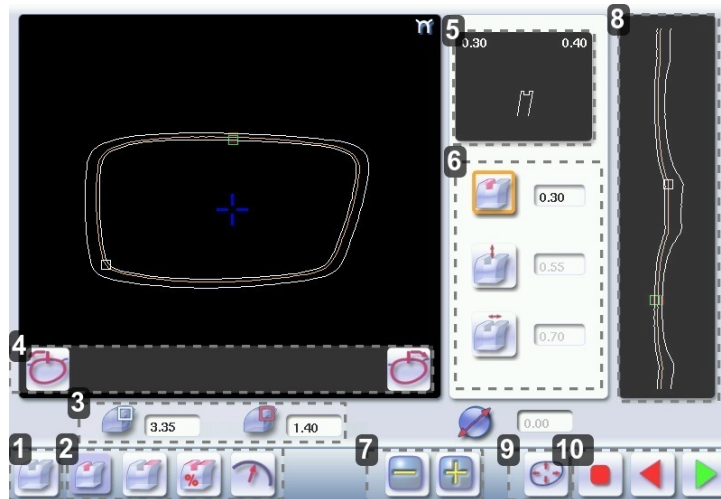

 - > The edging screen for the second lens is displayed. All finishes chosen and modifications made are kept.

b. Customized groove legend screen





1. Automatic groove

2. Customized grooves

-  Front surface tracking: the middle of the groove is positioned at a constant distance from the front surface.
-  Rear surface tracking: the middle of the groove is positioned at a constant distance from the rear surface.
-  Distributed groove: the middle of the groove is positioned in proportion to the thickness of the lens, with respect to the front surface.
-  Lens curve tracking: the camber of the groove is adjustable.

3. Lens thickness

-  Maximum lens thickness - represented by the white square along the shape
-  Minimum lens thickness - represented by the red square along the shape



4. Cursor movement

The cursor is represented by the green square along the shape. To move it, select it directly or use the buttons  and .

5. Zoom window

Distance between the edges of the groove and the front & rear surfaces of the lens at the position of the cursor.

6. Groove settings



-  Distribution value - according to the type of customized groove selected
-  Groove depth (in mm)
-  Groove width (in mm)

7. Modify the selected setting



8. Groove trajectory

Flat representation of the lens making it possible to measure the distances between the groove and the front & rear surfaces of the lens.

9. Modify the trajectory

-  General modification of the groove curve
-  Modification of a point in the groove curve
-  Displacement of the groove curve





10. Navigation



-  Stop the cycle
-  Return to the main edging screen

-  Start the edging cycle

c. Customized grooving





The use of the customized groove depends on 2 parameters: the frame and the lens. Before starting your job, identify the major constraint.

GROOVE	FRAME	LENS	ADVANTAGES
	Standard groove	Lens for which the front surface base is approximately equal to the frame base.	Makes it possible to do an aesthetically pleasing job. The lens material does not protrude beyond the front of the frame.
	Standard groove	Lens for which the rear surface base is not as high as the front surface base.	Minimises the risks of the nylon thread coming out.
	Standard groove	Thin lens	Makes it possible to balance out the groove when thin lenses are used.
	Flat base High base	Thin lens for which the base is approximately equal to the frame base.	In the event of pattern tracing (base = 0), makes it possible to retrieve the frame base.

- 1 Call the desired shape located on the tracer.
 - > The shape is displayed on the edger work screen.
 - > After tracing a pattern, demo lens or recut lens, without any drilling settings:
 - the groove finish is selected by default.
 - automatic mode is selected by default.
- 2 Select lens material.
- 3 Change the edging mode. To do this, press  to select the customized mode .
- 4 Select the type of cycle.
- 5 Choose whether or not to polish and/or chamfer your lens.



For more information, refer to the following section Edging > Polishing (p.61) and Edging > Chamfering (p.62).







- 6 Press .
 - > The door closes, the lens is clamped and then felt.
 - > The customized groove finish screen is displayed.
- 7 Select the type of customized groove you want to do.
- 8 Select the values you want to modify and press  and  to adjust them if necessary.
- 9 Press .
 - > The edging cycle starts.
 - > When the edging cycle is finished, the retouch screen is displayed.
- 10 Press  to release the lens.
- 11 If necessary, retouch the lens.

Otherwise, start edging the second lens. Select the lens directly on screen, on the left or right of the work area.

 - > The edging screen for the second lens is displayed. All finishes chosen and the modifications made are kept.



d. Modifying the groove curve

Once you have configured the desired type of customized groove, you can complete your customization by moving the groove curve towards the front or rear surface of the lens so it takes on its shape.

- 1 Press  in the customized groove finish screen.
 - > You will access the trajectory modification screen.
- 2 Press  to select the general modification of the groove curve.
- 3 Use the buttons  and  to move the groove curve:
 - Press  to move the curve towards the front surface of the lens.
 - Press  to move the curve towards the rear surface of the lens.









The curve cannot be moved more than the minimum distance between the front and rear surfaces observed on the groove before the modification.

- > The position of the groove as well as the distances between the center of the groove and the front & rear surfaces of the lens are displayed in the zoom window.
- 4 Press .
 - > The edging cycle starts.
 - > When the edging cycle is finished, the retouch screen is displayed.
 - 5 Press  to release the lens.
 - 6 If necessary, retouch the lens.
 - Otherwise, start edging the second lens. Select the lens directly on screen, on the left or right of the work area.
 - > The edging screen for the second lens is displayed. All finishes chosen and the modifications made are kept.

e. Modifying a point in the groove curve

Once you have configured the desired type of customized groove, you can complete your customization by moving the groove curve towards the front or rear surface of the lens so it takes on its shape.

- 1 Press  in the customized groove finish screen.
 - > You will access the trajectory modification screen.
- 2 Press  to select the modification of a point in the groove curve.
- 3 Using the cursor, select the point on the curve that you want to move or click directly on the screen.
- 4 Use the buttons  and  to move the selected point on the curve:
 - Press  to move it towards the front surface of the lens.
 - Press  to move it towards the rear surface of the lens.





The curve cannot be moved more than the minimum distance between the front and rear surfaces observed on the groove before the modification.

- > The position of the groove as well as the distances between the center of the groove and the front & rear surfaces of the lens are displayed in the zoom window.

- 5 Press .











 Press  to go back to the customized bevel finish screen.

- > For the second lens, the customized groove icon is pre-selected and the trajectory modification icon is displayed.

f. Displacement of the groove curve



The displacement of the groove curve enables you to move the groove without modifying its curve or perimeter.

- 1 Press  in the customized groove finish screen.
 - > You will access the trajectory modification screen.
- 2 Press  to select the displacement of the curve.
- 3 Use the buttons  and  to displace the curve:
 - Press  to displace it towards the front surface of the lens.
 - Press  to displace it towards the rear surface of the lens.
 - > The position of the groove as well as the distances between the center of the groove and the front & rear surfaces of the lens are displayed in the zoom window.
- 4 Press .
 - > The edging cycle starts.
 - > When the edging cycle is finished, the retouch screen is displayed.
- 5 Press  to release the lens.
- 6 If necessary, retouch the lens.
 - Otherwise, start edging the second lens. Select the lens directly on screen, on the left or right of the work area.
 - > The edging screen for the second lens is displayed. All finishes chosen and the modifications made are kept.

6. Flat-edge finishing

To do a flat-edge finish, only the automatic mode  is accessible.

- 1 Call the desired shape located on the tracer.
 - > The shape is displayed on the edger work screen.
- 2 Select lens material.
- 3 Press  to select the flat-edge finish.
- 4 Select the type of cycle.
- 5 Choose whether or not to polish and/or chamfer your lens.

 For more information, refer to the following section [Edging > Polishing \(p.61\)](#) and [Edging > Chamfering \(p.62\)](#).
- 6 Press .
 - > The door closes, the lens is clamped and then felt.
 - > The edging cycle starts.
 - > When the edging cycle is finished, the retouch screen is displayed.
- 7 Press  to release the lens.
- 8 If necessary, retouch the lens.

Otherwise, start edging the second lens. Select the lens directly on screen, on the left or right of the work area.

- > The edging screen for the second lens is displayed. All finishes chosen and the modifications made are kept.

7. Mixed job

In this section, you will find the required procedure to do a mixed job:

- Description of the legend screens (p.56)
- Configuring the mixed finish (p.57)

This finish enables you to do mixed jobs such as the following:

- Groove - Groove
- Bevel - Groove
- Flat-edge - Groove
- Flat-edge - Bevel



To do a mixed finish, you need to define the points between which the two types of finish will be done. Only the customized mode  is thus accessible.

a. Legend screens

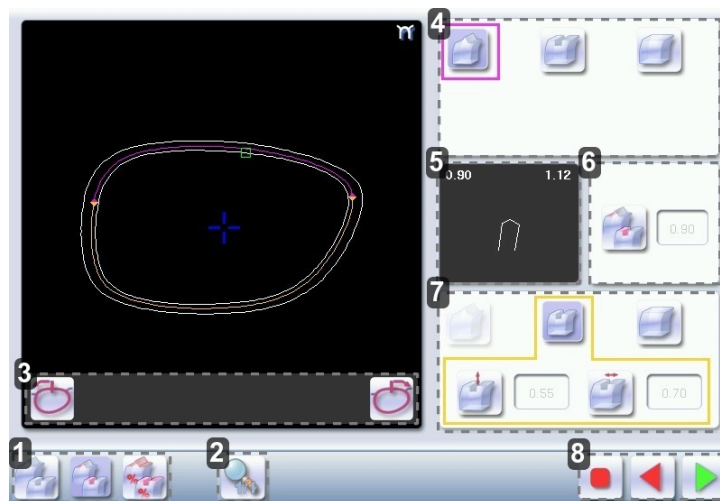
Main screen for mixed jobs





1. Modes available for a mixed finish

-  Automatic mode: the position of the bevel or groove is automatically calculated according to the information acquired when tracing the frame and feeling the lens.
-  Front surface tracking: the crest of the bevel or the middle of the groove is positioned at a constant distance from the front surface.
-  Distributed mixed finish: the crest of the bevel or the middle of the groove is positioned in proportion to the thickness of the lens, with respect to the front surface.

2. Access to the area defining screen

Access on a 1:1 scale.

3. Cursor movement

The cursor is represented by the green square along the shape. To move it, select it directly or use the buttons  and .

4. Settings for area 1

-  Bevel finish
-  Groove finish
-  Flat-edge finish

5. Zoom window

Display of the distance from the edges of the lens to the position of the cursor.



6. Position of the center of the groove or bevel

Value expressed in mm ('Front surface tracking' mode) or in % ('Distributed mixed finish' mode).

7. Settings for area 2

-  Bevel finish
-  Groove finish
-  Flat-edge finish

8. Navigation

-  Stop the cycle
-  Back to the main edging screen without saving your modifications
-  Start the edging cycle

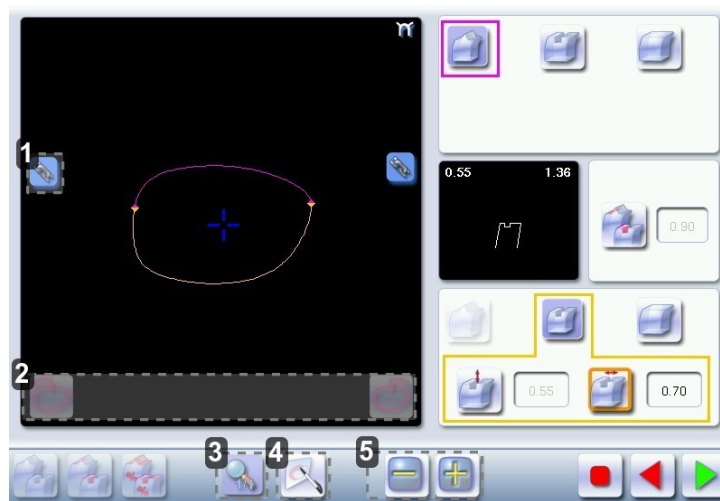

Area definition screen



1. Lock / unlock the area delimitation points
2. Move the area delimitation points
3. Back to the main screen
4. Enable area delimitation on the touch screen
5. Modify the selected value

Legend of the colours delimiting the areas of the shape:

 (pink) Bevel finish

 (yellow) /  (orange) Groove finish (in the case of a Groove - Groove mixed job, the colours make it possible to differentiate grooves with different parameters)

 (black) Flat-edge finish

b. Configuring the mixed finish

Initiating a mixed finish

- 1 Call the desired shape located on the tracer.
 - > The shape is displayed on the edger work screen.
- 2 Select lens material.
- 3 Press  to select the mixed job mode.
- 4 Select your type of cycle.

- 4
5 Choose whether or not to polish the lens.



You cannot do a chamfer on a mixed job.

For more information on polishing, refer to the following section: Edging > Polishing (p.61).

- 6 Press .

- > The door closes, the lens is clamped and then felt.
- > The mixed finish screen is displayed:
- > The default setting is the bevel - groove finish in automatic mode.

Customizing the mixed finish

- 1 Select the desired type of mixed finish.

- 2 Press  to access the area definition screen.

- > The area definition screen is displayed on a 1:1 scale. You can thus refer to a sample lens placed on the screen.

- 3 Select the finish you want to do in area 1, then area 2.

- 4 Press one of the buttons  to unlock an area delimitation point.

- 5 Press the buttons  and  to move the unlocked point.



Press  to move the delimitation points directly on the touch screen. The two points are then unlocked. Drag them with the stylus.

- 6 If required, press  to modify the position of the center of the groove or bevel using the buttons  and .



This value cannot be modified in automatic mode.

- 7 If required, press  and  to modify the depth and width of the groove using buttons  and .

- 8 Press .

- > The edging cycle starts.
- > When the edging cycle is finished, the retouch screen is displayed.

- 9 Press  to release the lens.

- 10 If necessary, retouch the lens.



Otherwise, start edging the second lens. Select the lens directly on screen, on the left or right of the work area.

- > The edging screen for the second lens is displayed. All finishes chosen and the modifications made are kept.

8. Drilled job

 Prerequisite: the edger's drilling function is only accessible if the tracer sends a shape with drilling settings. For further information, refer to the following chapter: *Preparing a drilled job* from the tracing manual.

You can do the drilling in automatic mode or in customized mode:

-  In automatic mode (p.59), you have nothing to configure. The drilling angle consists of the average value calculated at right angles with the front surface of the lens for each drilling point. The lens edging starts automatically after the feeling cycle.
-  In customized mode (p.61), you can do the following:

- Drilling at right angles with the front or rear surface: you can modify the diameter but not the drilling angle which is automatically calculated by the edger based on the lens curve.
- Customized drilling: you can modify the diameter and angle for each drilling point.
- You can refer to the description of the customized hand drilling screen (p.60).

Two different diameter drill bits are available: a 1 mm bit and a 0.8 mm bit. If the diameter of the drilling point is smaller than that of the installed drill bit, an error message is displayed. Change the drill bit or modify the diameter of the drilling points.



You can also create various combinations:



- Drilled bevel
- Drilled high-base bevel
- Drilled groove
- Drilled mixed finish

a. Automatic drilling

- 1 Call the desired shape located on the tracer.
 - > The shape is displayed on the edger work screen.
 - > After the tracing of a shape with drilling settings:
 - The drilling function is selected by default.
 - The automatic mode is selected by default.
- 2 Select lens material.
- 3 Select the type of finish.
- 4 Select the type of cycle.
- 5 Choose whether or not to polish and/or chamfer your lens.





For more information, refer to the following section Edging > Polishing (p.61) and Edging > Chamfering (p.62).

- 6 Press .
 - > The door closes, the lens is clamped and then felt.
 - > The edging cycle starts.
 - > When the edging cycle is finished, the retouch screen is displayed.
- 7 Press  to release the lens.
- 8 If necessary, retouch the lens.
Otherwise, start edging the second lens. Select the lens directly on screen, on the left or right of the work area.
 - > The edging screen for the second lens is displayed. All finishes chosen and the modifications made are kept.

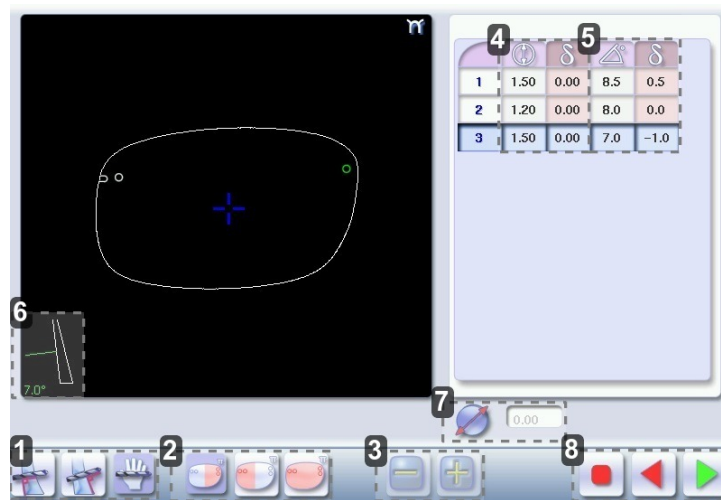

b. Legend screen for customized drilling



1. Type of drilling



-  Perpendicular to the front surface
-  Perpendicular to the rear surface
-  Customized

2. Select the drilling points



-  Nasal side
-  Temporal side
-  All drilling points

3. Modify the selected value

4. Modify the diameter

-  diameter (mm)
-  difference between the initial value and the modified value

5. Modify the drilling angle



-  drilling angle (degrees)
-  difference between the initial value and the modified value

6. Cross-sectional view



Cross-sectional view of the lens after the feeling cycle, showing the angle of the drill bit at the selected drilling point.





7. Reminder of the size reduction / increase applied to the lens diameter

8. Navigation

-  Stop the cycle
-  Back to the main edging screen without saving your modifications
-  Start the cycle

c. Customized drilling

- 1 Call the desired shape located on the tracer.
 - > The shape is displayed on the edger work screen.
 - > After the tracing of a shape with drilling settings:
 - The drilling function is selected by default.
 - The automatic mode is selected by default.
- 2 Select lens material.
- 3 Change the edging mode. To do this, press  to select the customized mode .
- 4 Select the type of cycle.
- 5 Choose whether or not to polish and/or chamfer your lens.











 For more information, refer to the following section Edging > Polishing (p.61) and Edging > Chamfering (p.62).
- 6 Press .
 - > The feeling cycle starts.
 - > The customized drilling screen is displayed.
- 7 Select the type of drilling you want to do.
- 8 If necessary, select the drilling point(s) you want to modify.
- 9 If necessary, modify the diameter and/or angle of the selected drilling point.
 - > The difference between the initial value and the modified one is displayed in the delta column.
- 10 Press .
 - > The edging cycle starts.
 - > When the edging cycle is finished, the retouch screen is displayed.
- 11 Press  to release the lens.
- 12 If necessary, retouch the lens.



Otherwise, start edging the second lens. Select the lens directly on screen, on the left or right of the work area.

 - > The edging screen for the second lens is displayed. All finishes chosen and the modifications made are kept.

9. Polishing

Press button  to enable/disable the polishing option.

LENS MATERIAL	AVAILABLE OPTIONS
	 
	  The polishing option is pre-selected and is strongly recommended by the manufacturer to prevent small cracks.
	  Make sure you select the correct type of material for MHI (> 1.5) or Tribrid lenses and never polish a lens of this type without water. Otherwise, the polishing wheel could suffer irreversible damage.
	 

	The polishing option is pre-selected.
	

 The polishing option is not available for high-base jobs. However, the high-base wheel has been designed to provide an equivalent finish on polycarbonate lenses.







10. Chamfering

The chamfer, also called counter-bevel, removes the sharp edge of the lens.



- Standard value of a small chamfer: 0.20 mm
- Standard value of a large chamfer: 0.40 mm

Before you select a type of chamfer, make sure it is compatible with the lens characteristics:



- Lens material

LENS MATERIAL	AVAILABLE OPTIONS
	
	 The quality of the chamfer depends on the spraying. Make sure there is a constant flow of water until the end of the chamfering operation.
	 The chamfering wheel supplied cannot be used on glass lenses. For further information, contact your technical department.



- Thickness at the edge of the lens

LENS THICKNESS	AVAILABLE OPTIONS
> 1.2 mm	
between 1 and 1.2 mm	
< 1 mm	

- Distance between the edge of the groove and the edge of the lens

DISTANCE	AVAILABLE OPTIONS
> 0.8 mm	
between 0.5 and 0.8 mm	
< 0.5 mm	

The chamfers available also depend on the lens shape and the posiblock used when blocking.

Press the buttons  and  to configure a small chamfer, a large chamfer or no chamfer on the front and rear surfaces of the lens.

11. Perform a Retouching

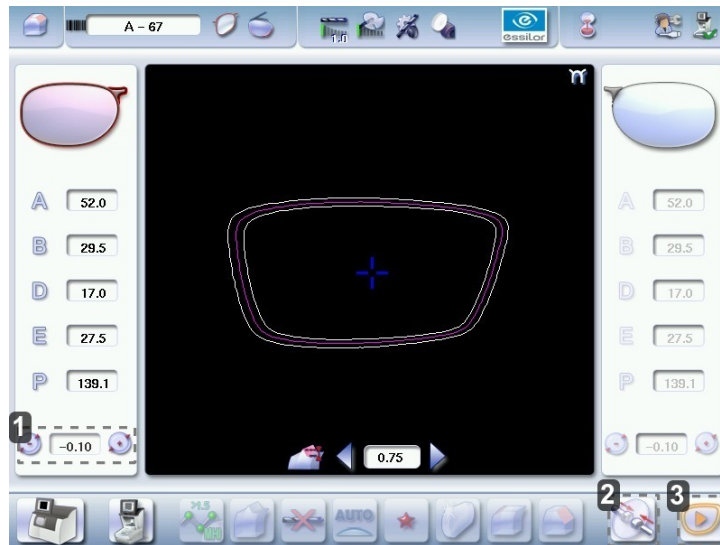

1. Diameter modification
2. Manual lens clamping
3. Retouch launch





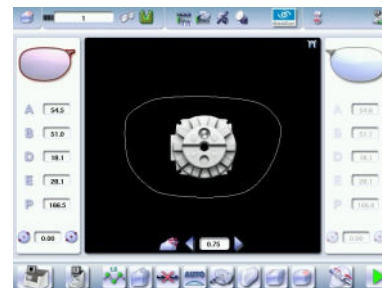

Differences with the edging screen

The edging screen is different to the retouch screen through:

- the presence of the posiblock
- no frame thickness
- the edging start-up button 



When the first-lens edging cycle is finished:

- 1 Press  to release the lens.
- 2 Proceed to lens assembly and check that edging was correctly configured.
 - > Depending on your job:
 - If your job is perfect, proceed with the machining of your second lens.
 - > All of the selected finishing options and modifications made are kept.
 - If the lens requires adjustment, do a retouch on the edged lens to obtain optimal results.
- 3 Indicate the size reduction to be applied to the lens you want to retouch.
 - > The chosen finish and the modifications made during the edging cycle are automatically selected.
- 4 Insert the lens in the posiblock holder.
 -  To close the clamp shafts manually, do a long press on .
- 5 Press .
 - > For a customized finish, the customized finish screen is displayed.
 - > In all other cases, the door closes, the lens is clamped automatically, then the retouching starts.

- 6 Select the second lens to be edged directly on screen, on the left or right of the work area.
 - > The edging screen for the second lens is displayed.
 - > All finishes chosen and the modifications made are kept. The retouch done on the first lens is automatically saved for the edging of the second lens.

III. CONFIGURING THE EDGER

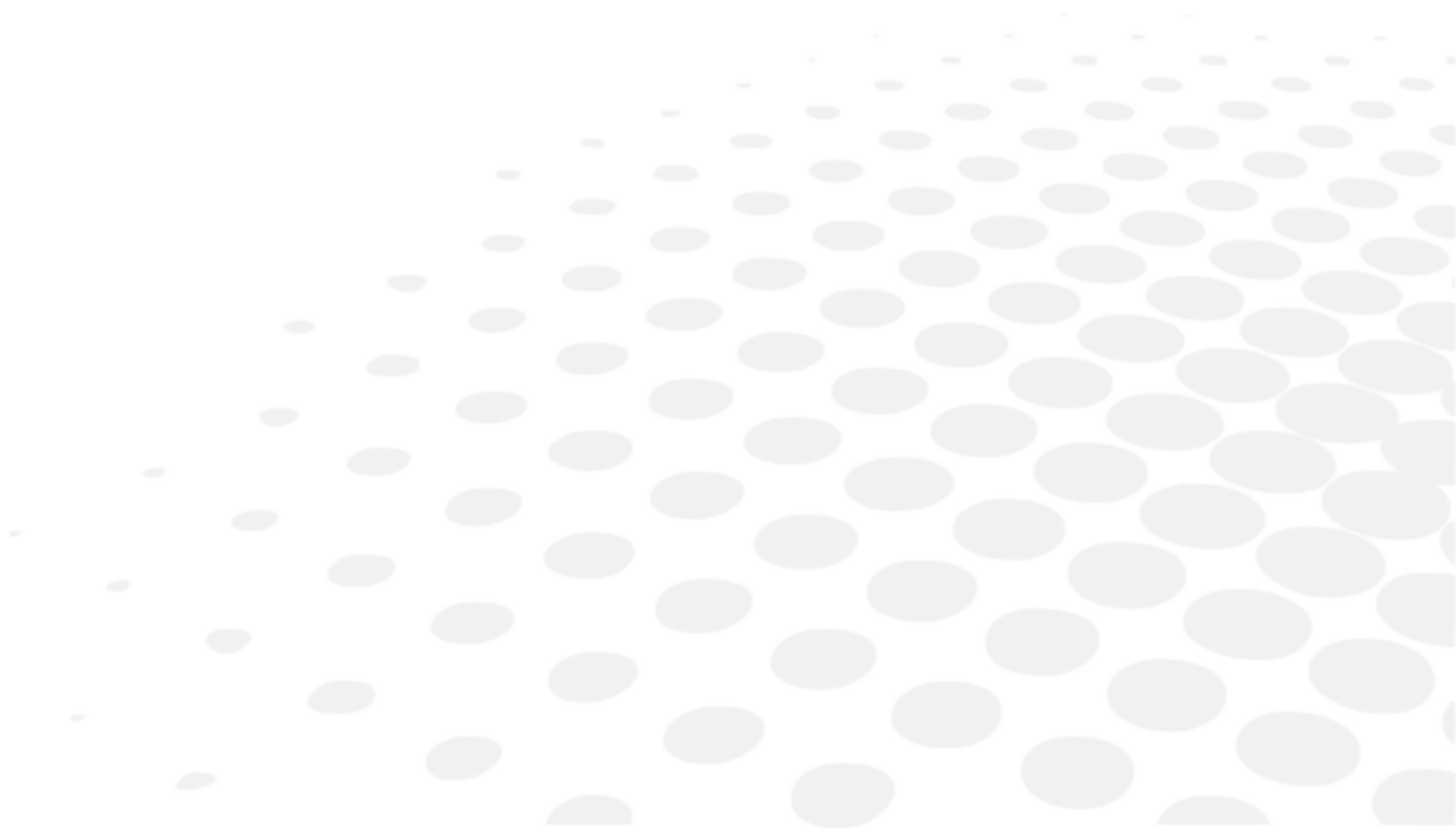

This chapter allows you to set up the edger according to your use. You can:



- Configure the edger (p.67) (hour, date, language, logins, screen-saver)
- Adjust the precision of the edger (p.68)
- Restore the factory settings (p.75)

1. Configure the edger

This section describes the procedures to:

- Set the time, date and language (p.67)
- Access the connections and the network (p.68)
- Configure a screensaver (p.68)



a. Time, date and language

To access this menu from your work screen, select  >  > .



The following screen is displayed:



1. Time

Use the arrows  and  to set the time.

2. Date

Use the arrows  and  to set the date.

3. Type of date display

Select the type of display out of the available formats.

4. Language

Select the flag corresponding to your language.

5. Other languages

Press  to display the other languages.



6. Confirm

Press  to save the time.

Once the settings has been adjusted, press  to go back to the work screen.

b. Connections

The connections are configured from the tracer. The screen which you access from the edger is only available for consultation purposes.

To access this menu from your tracer work screen, select  >  > .

The following screen is displayed:

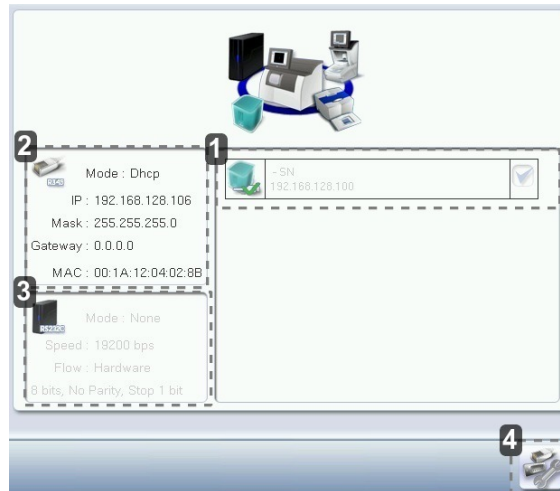

1. List of devices connected to the tracer
2. Settings linked to the configuration of the serial port
3. Settings linked to the configuration of the Ethernet port
4. Reinitialization of communication ports

Once the change has been made, press  to return to the work screen.



c. Screensaver

This menu enables you to configure a screensaver.

To access this menu from your work screen, select  >  > .

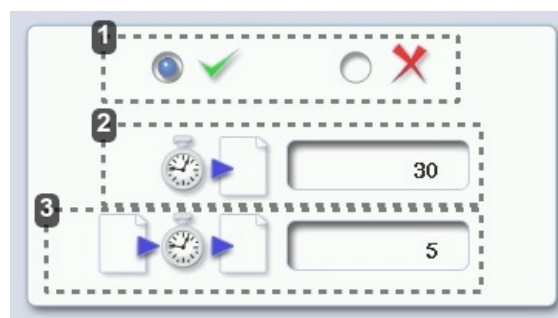
The following screen is displayed:



1. Screensaver display
Enable  or disable  the screensaver.
2. Triggering
Set the waiting time before the display of the screensaver (in seconds).
3. Transition
Set the transition time between each image (in seconds).

Once the modification has been made, press  to go back to the work screen.



2. Adjusting the precision of the edger

This menu enables you to adjust the precision of the edger. You can adjust:

- the diameter of the finished lenses (p.69)
- the position of the bevel and groove (p.70)
- the diameter of drill holes (p.70)
- the chamfer (p.71)
- the depth and width of the groove (p.72)
- engraving: number of strokes of the engraving tip. (p.72)
- the position of high-base bevel (p.73)
- the position of the step bevel (p.74)









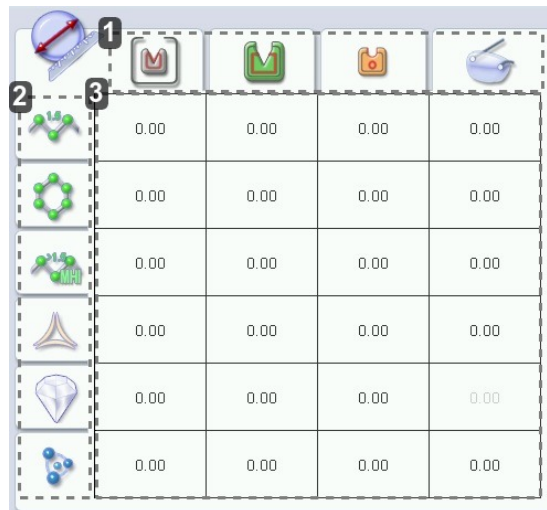

a. Adjusting the diameter of the finished lenses

If lenses of a particular material always seem too small or too big after edging, you can adjust their diameter according to the type of frame.

To access that menu from your edger's work screen, select  >  > .

The following screen is displayed:



				
	0.00	0.00	0.00	0.00
	0.00	0.00	0.00	0.00
	0.00	0.00	0.00	0.00
	0.00	0.00	0.00	0.00
	0.00	0.00	0.00	0.00

1. Frame types

- Metal
- Plastic
- Optyl
- Drilled / Grooved / Flat

2. Lens materials

- Plastic
- Polycarbonate
- MHI
- Trivex™
- Glass
- Tribrid™

3. Adjust the lens diameter



1. Press the value to be modified.
 - > The numeric keypad is displayed.
2. Enter the new value.
 - Negative value: the diameter will be smaller
 - Positive value: the diameter will be larger

3. Press  to confirm.

Once the modification has been made, press  to go back to the work screen.

b. Adjusting the position of the bevel and groove



After edging a lens, if the position of the bevel or groove always seems too close to the front or rear surface, you can adjust it.

To access that menu from your edger's work screen, select  >  > .

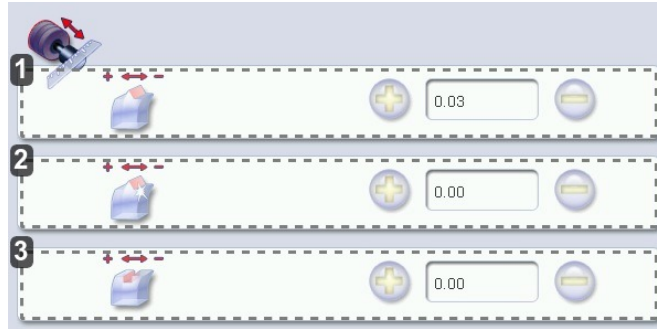

The following screen is displayed:





1. Default bevel position

- Press  to move the bevel towards the front surface of the lens.
- Press  to move the bevel towards the rear surface of the lens.

2. Default polished bevel position

- Press  to move the polished bevel towards the front surface of the lens.
- Press  to move the polished bevel towards the rear surface of the lens.



3. Default groove position

- Press  to move the groove towards the front surface of the lens.
- Press  to move the groove towards the rear surface of the lens.

Once the modification has been made, press  to go back to the work screen.

c. Adjusting the diameter of drill-holes

After drilling a lens, if the diameter of the holes always seems too small or too big, you can adjust it according to the diameter of the drill bit used and the lens material.

To access that menu from your edger's work screen, select  >  > .

The following screen is displayed:

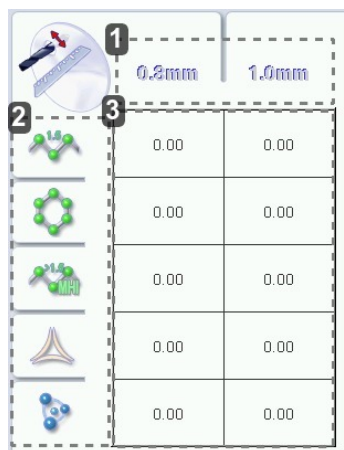

1. *Drill bit diameters*

0.8 mm or 1.0 mm.

2. *Lens materials*

- Plastic
- Polycarbonate
- MHI
- Trivex™
- Tribrid™



3. *Increasing or reducing the default drill-hole diameter*

1. Press the value to be modified.
> The numeric keypad is displayed.
2. Enter the new value.
 - Negative value: the hole will be smaller
 - Positive value: the hole will be larger
3. Press  to confirm.

Once the modification has been made, press  to go back to the work screen.

d. Adjusting the chamfer

After edging a lens, if a chamfer always seems too small or too big, you can adjust its size according to the lens material.

To access that menu from your edger's work screen, select  >  > .

The following screen is displayed:

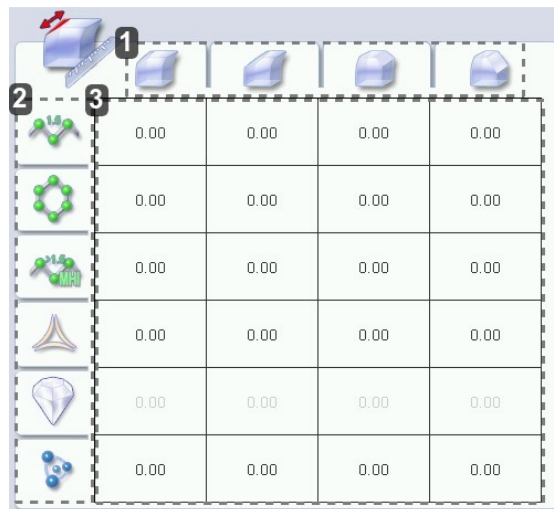

1. *Chamfer*

- Small, front surface
- Large, front surface
- Small, rear surface
- Large, rear surface

2. *Lens materials*

- Plastic
- Polycarbonate
- MHI
- Trivex™
- Tribrid™
- Glass



3. Increasing or reducing the default chamfer

1. Press the value to be modified.
> The numeric keypad is displayed.
2. Enter the new value.
 - Negative value: the chamfer will be smaller
 - Positive value: the chamfer will be larger
3. Press  to confirm.

Once the modification has been made, press  to go back to the work screen.

e. Adjusting the groove



After edging a lens, if the width or depth of the groove always seem too close too small or too big, you can adjust them.

To access that menu from your edger's work screen, select  >  > .

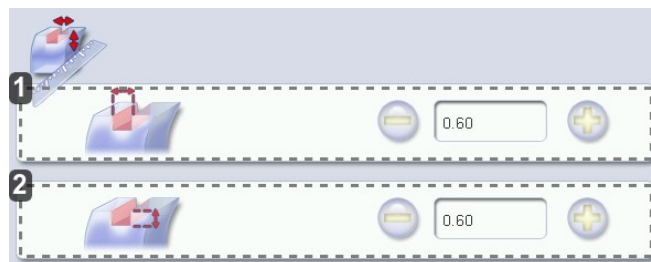

The following screen is displayed:



1. Adjusting the default groove width

- Press  to reduce the width of the groove.
- Press  to increase the width of the groove.

2. Adjusting the default groove depth



- Press  to reduce the depth of the groove.
- Press  to increase the depth of the groove.

Once the modification has been made, press  to go back to the work screen.

f. To adjust the engraving

After lens engraving, if the motif is not clear enough, you can restart another stroke by pressing .

It is also possible to change the number of strokes per material.

To access that menu from your edger work screen, select  >  > .

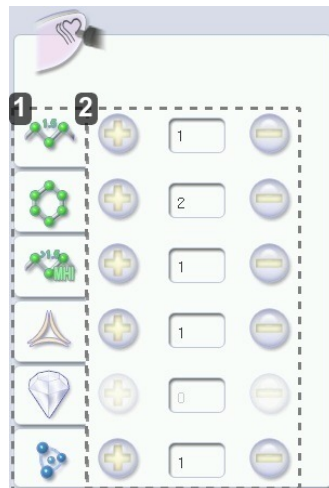

The following screen is displayed:



1. Lens materials

- Plastic
- Polycarbonate: it is recommended to set the value to 2 minimum.
- MHI
- Trivex™
- Tribid™
- Glass: you cannot engrave glass.

2. To adjust the number of tool strokes depending on the material :

- Press  to increase the number of strokes.
- Press  to reduce the number of strokes.

This screen allows to adjust the number of default strokes.

If two strokes are programmed by default for the plastic lens, each time you launch the engraving cycle for a lens, the tool will make 2 strokes without stopping.





It is possible to carry out a third stroke after checking the lens by pressing .

Once the modification is made, press  to return to the work screen.

g. Adjust the position of high-base bevel

After lens edging, if the position of high-base bevels seems consistently too far ahead or too far behind, you can adjust it.

To access this menu from your edger work screen, select  >  > .

The following screen is displayed:

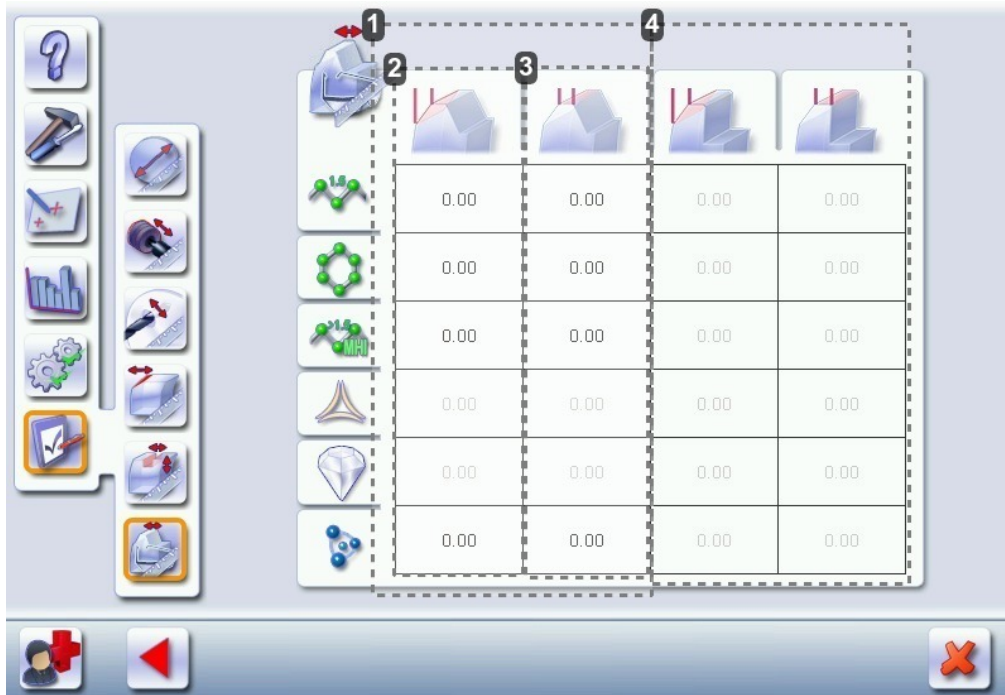

1. High-base bevel

2. Increase or reduce the front surface tracking value

1. Press the value to be modified.
> The numeric keypad is displayed.
2. Enter the new value.
 - Negative value: the front surface tracking value will be smaller
 - Positive value: the front surface tracking value will be larger
3. Press  to confirm.

3. Increase or reduce the flat side of the bevel



1. Press the value to be modified.
> The numeric keypad is displayed.
2. Enter the new value.
 - Negative value: the flat side of the bevel will be smaller
 - Positive value: the flat side of the bevel will be larger.
3. Press  to confirm.

4. Step bevel is not accessible if the high-base tool is in place

For more information, consult the section [Setting the edger > Adjusting the precision of the edger > Adjusting the step bevel](#) (p.74)

h. Adjust the position of the step bevel

After the edging of a lens, if the position of high-base bevel or step bevel seems consistently too far ahead or too far behind, you can adjust it.

To access that menu from your edger work screen, select  >  > .

The following screen is displayed:

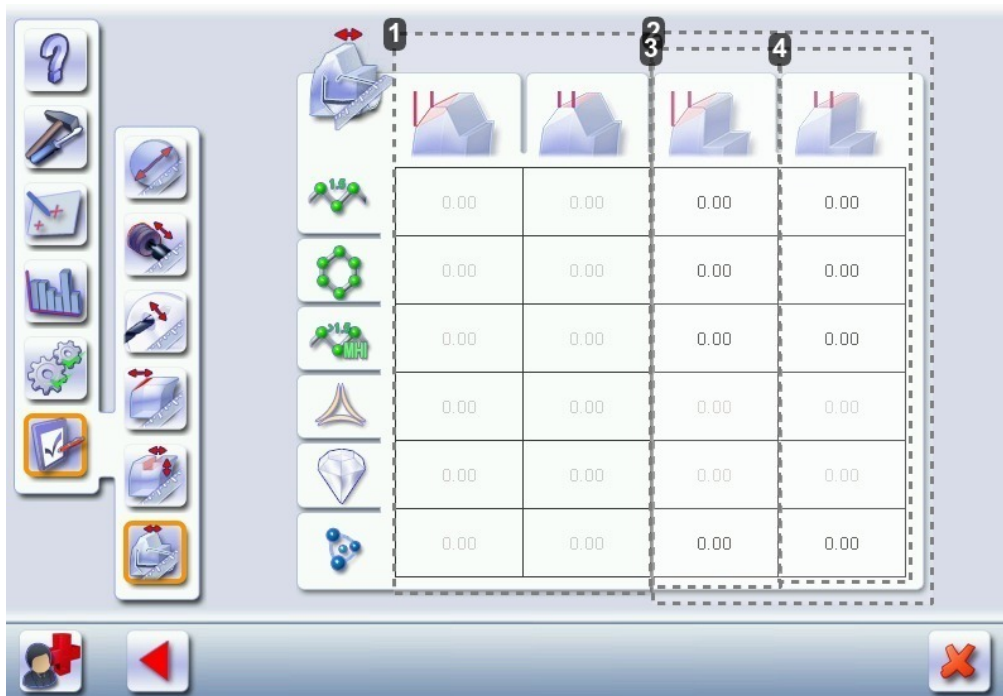

1. High-base bevel non accessible if the step bevel tool is in place

For more information, consult the section *Setting the edger > Adjusting the precision of the edger > Adjusting the high-base bevel* (p.73)

2. Step bevel

3. Increase or reduce the front surface tracking value

1. Press the value to be modified.
> The numeric keypad is displayed.
2. Enter the new value.
 - Negative value: the front surface tracking value will be smaller
 - Positive value: the front surface tracking value will be larger
3. Press  to confirm.

4. Increase or reduce the flat side of the bevel

1. Press the value to be modified.
> The numeric keypad is displayed.
2. Enter the new value.
 - Negative value: the flat side of the bevel will be smaller
 - Positive value: the flat side of the bevel will be larger.
3. Press  to confirm.

3. Restore the factory settings

At the bottom right of certain settings screens, the  button enables you to restore the page's factory settings.



- Press  to cancel and go back to the settings screen.

- Press  to confirm the reset.

IV. MAINTENANCE & SERVICING

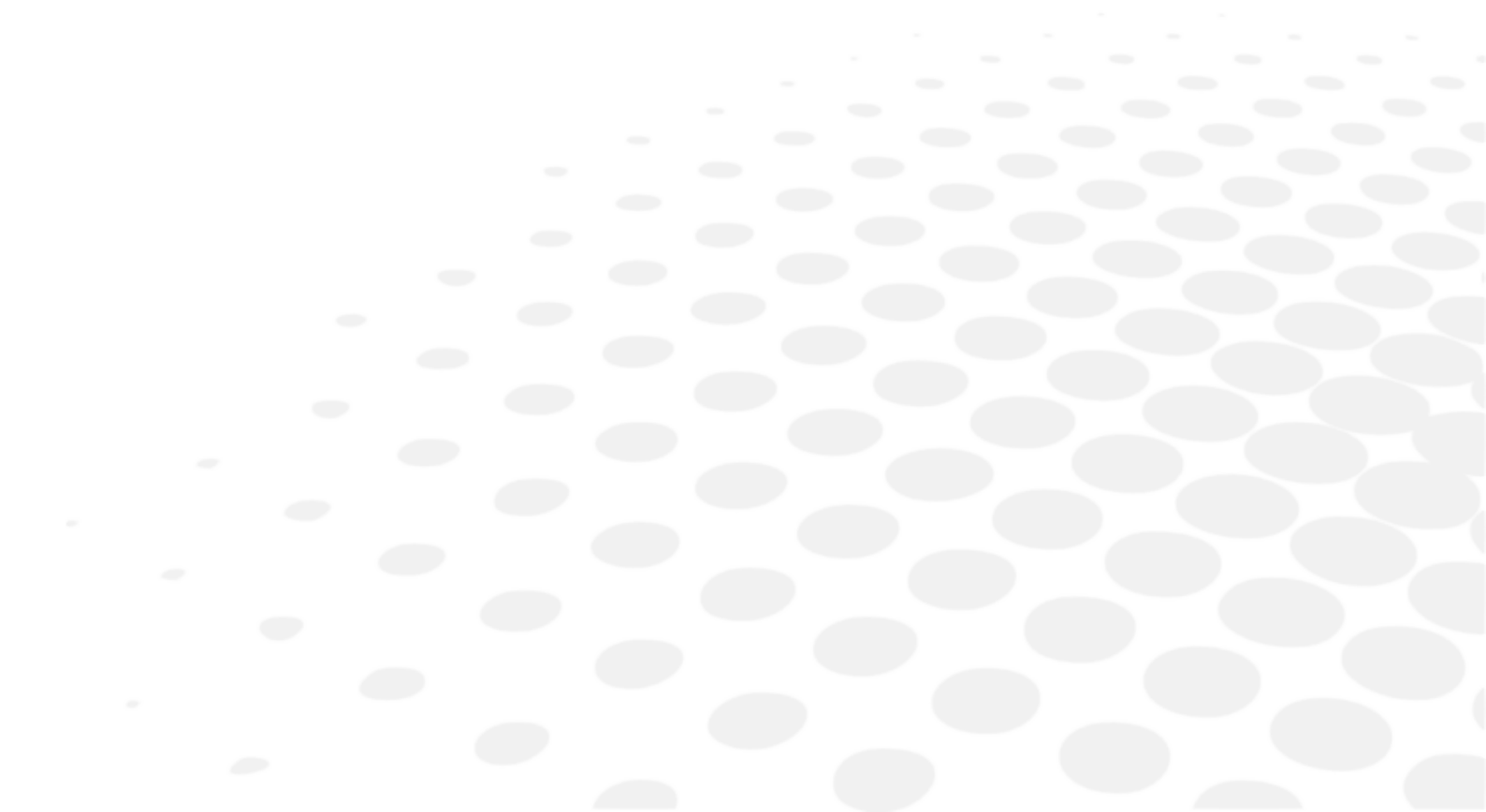



This chapter describes the maintenance procedures you can carry out on the edger without the aid of a technician.

- Carrying out the digital system autotests (p.79)
- Calibrating the touch screen (p.80)
- (p.88) Consulting the preventive maintenance screen of the “small tools” module (p.80)
- Changing the edger tools (p.82)
- Viewing the statistics and technical history (jobs and actions carried out) (p.88)
- Servicing and cleaning the digital system (p.90)

1. Carrying out the autotests

You can use this menu to carry out a self-diagnosis of the job functions of the edger.

To test the proper performance of the edger, select  >  >  from your work screen.

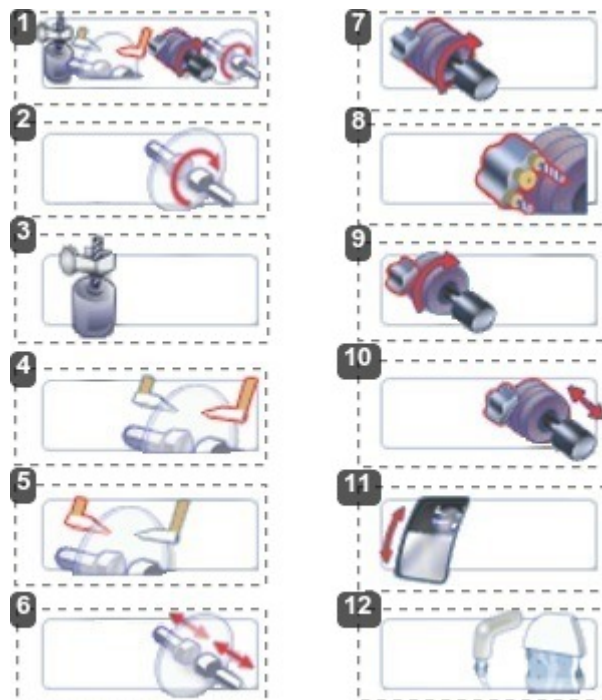

1. *Edger autotests*
2. *Initialisation and rotation of lens shafts*
3. *Reproducer: lens shaft raising and lowering*
4. *Right feeler movement*
5. *Left feeler movement*
6. *Closing of lens shafts*
7. *Wheel rotation*
8. *Rotation of Grooving/Milling/Drilling (GMD) module*
9. *Movement of Grooving/Milling/Drilling (GMD) module*
10. *Transfer initialization*
11. *Door*
12. *Water test*
 - trough spraying
 - door spraying

1. Select the autotest to be carried out.

2. Press  to start the test cycle.

You can press  to stop the cycle at any moment.

> The result is displayed on the right of the icon of the autotest carried out:

-  The equipment is operational.
-  A malfunction has been detected; a description is displayed in the message box on the right.

2. Calibrating the touch screen

Calibrate the touch screen if your operations have become difficult due to lack of precision.





Touch screen malfunction

You can directly access the calibration screen without using the settings menu. To do this, press on the edging screen for 5 seconds.

Calibrating the touch screen

1 Select  >  in the work screen.

> A confirmation message is displayed:

- Press  to start the calibration.
- Press  to cancel and go back to the menu.



2 Point precisely on each cross as they are displayed, holding the stylus perpendicular to the screen so as not to alter the calibration.

> The settings menu is displayed automatically once the calibration is finished.

3 Press  to go back to the work screen.

3. Consult the preventive maintenance screen of the “small tools” module

This menu enables you to know the level of wear of your “small tools” module.

To access this menu from your work screen, select  >  > .

The maintenance screen appears:

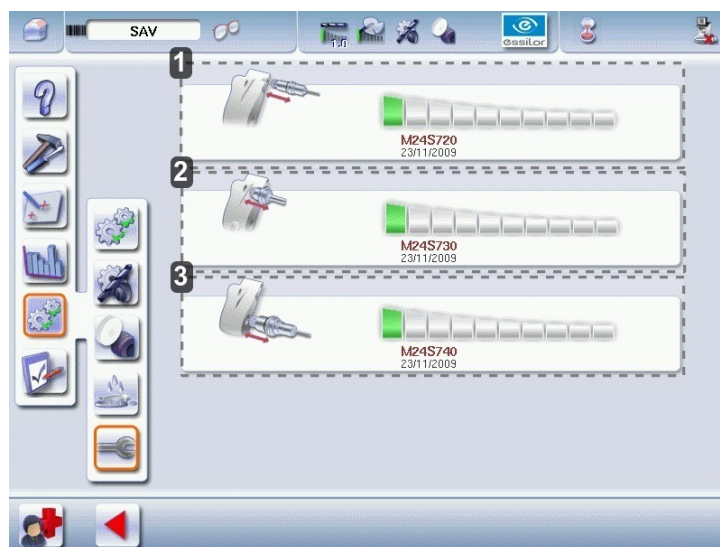

1. *Wear indicator of the drilling spindle*
2. *Wear indicator of the chamfering/high-base bevel spindle*
3. *Grooving/milling spindle wear-out indicator*



At the time of installation of the machine, there is no date displayed, it is the first edging which starts the initialization and the taking into account of the installation date.

There exist 3 wear thresholds:

First wear-out threshold

The icon  appears beside the small maintenance access button, press to access directly the preventive maintenance menu of the "small tools" module:



Second wear-out threshold

An alarm appears upon start-up "Maintenance is needed. Have you contacted your service technician?"

The icon  appears beside the small maintenance access button and flashes: press above to directly access the preventive maintenance menu of the "small tools" module:

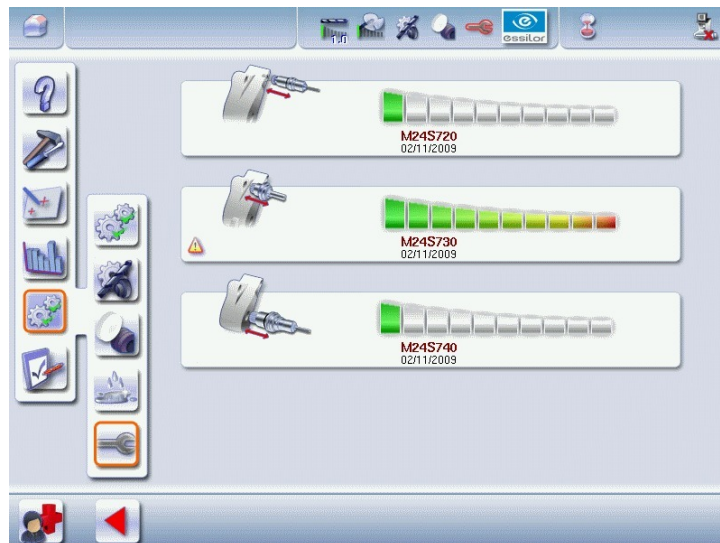

The icon  appears on the worn spindle.

Third wear threshold

An alarm appears:

- at start-up: "Module maintenance needed urgently. Please contact your support technician."
- at each cycle launch: " Proper functioning of a component is no longer assured. This could impact the edging of your lenses. Continuing could also call into question your existing guarantees. Do you wish to continue?"







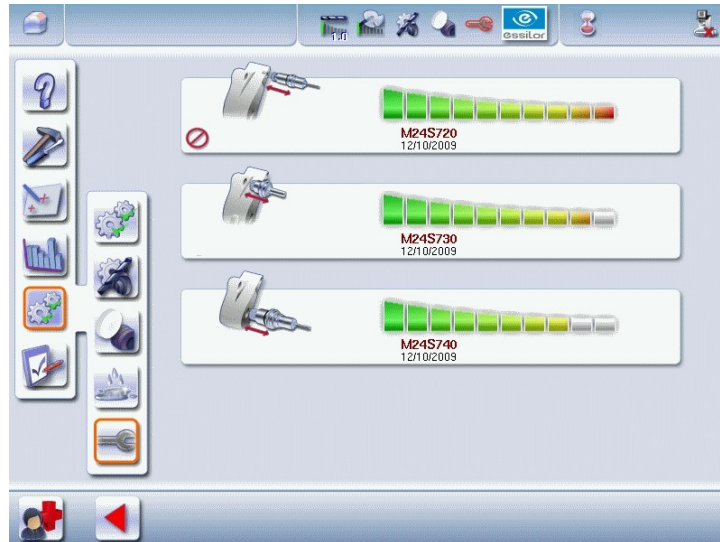

At least one of the spindles has reached 100% wear and must be replaced immediately.

The icon  appears beside the small maintenance access button and flashes: press above to directly access the preventive maintenance menu of the "small tools" module:



The bargraph flashes and the icon  appears on the spindle that needs to be replaced.

A red key appears on the finish icons related to the GMD module functions.

-  milling
-  drilling
-  grooving
-  mixed finish
-  chamfering (small chamfer)
-  chamfering (large chamfer)

4. Changing or cleaning the edger tools

This menu enables you to change the tools of the edger's GMD module:





- to replace them with tools of a different diameter (drill bits) or clean them (mill bit and drill bit),
- to replace them with new tools,

You can replace:

-  The mill bit
-  The drill bit
-  The engraving tip

Wear indicators



Four indicators in the information bar inform you of the level of wear of certain tools:

-  Wear of the 1.0 mm or 0.8 mm drill bit
-  Mill bit wear
-  Wear of the wheels: high-base wheel,
-  Wear of the step bevel wheel
-  Dressing of the polishing wheel: press above to directly access the dressing menu

The colour of the indicator informs you of the level of wear of the tool:

- Green for a new tool

- Blinking red  for a worn-out tool that needs to be changed: press on it to directly access the tool change menu.

The indicator  enables you to know the level of wear of the spindles (change by a technician only): press  to directly access the spindle preventive maintenance.



- Always use tools recommended by Essilor.
- Never use the edger if one of the tools is missing from the module. Never remove a used or broken tool if you cannot replace it.
- All tools coming into contact with the module must be clean and dry in order to prevent water from seeping into the mechanisms.
- The use of broken tools may cause lens breakage or errors with respect to lens shape or drill-hole diameter: change the tools as soon as they are worn (check the indicators and statistics of your digital system).
- Incorrect positioning of the tools may cause breakage or errors with respect to lens shape or drill-hole diameter: fully insert the tools and tighten the screws as much as possible.

a. Changing or cleaning the mill bit

The wear indicator informs you of the need to change the mill bit once you have machined 500 lenses.



Milling of MHI lenses



The mill bit wears 2.5 times faster with MHI lenses.

The wear indicator of the mill bit  may be triggered when for example:

- 100 MHI lenses and 250 lenses made of other materials have been edged: $(100 \times 2.5) + 250 = 500$
- 200 MHI lenses have been edged: $200 \times 2.5 = 500$
- 500 lenses made of other materials have been edged:

From the work screen of your edger, select  >  >  to change the mill bit.

1 Select the type of operation:

-  Installing a new mill bit: at the end of the procedure, the wear statistics will be reset to zero.
-  Cleaning the mill bit in place: the wear statistics will not be reset to zero.

2 Press .

> The GMD module moves to facilitate the operation.

3 Insert the mill bit replacement tool at the base of the chuck.

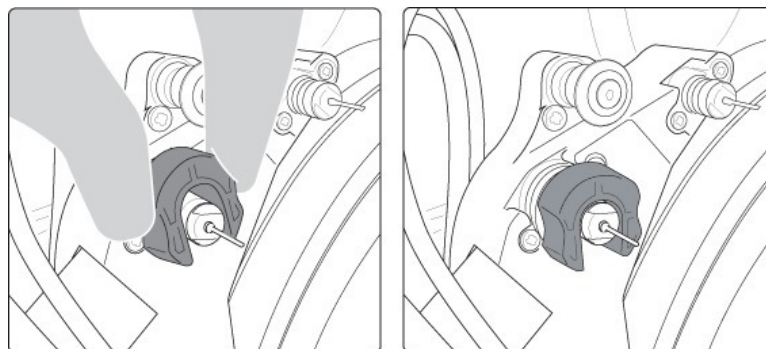

> The chuck is loosened.

4 Remove the mill bit and replace it.

5 Hold the mill bit all the way in against the back of the chuck then remove the mill bit replacement tool .

> The chuck tightens up. The mill bit is in place.

6 Press .

- > The module goes back into its initial position.
- > When you install a new mill bit, the wear statistics are reset to zero.

b. Changing or cleaning the drill bit

The wear indicator informs you of the need to change the 0.8 mm drill bit every 250 holes and the 1.0 mm bit every 500 holes.



The chuck must always contain a tool to avoid any risk of oxidation.

✓ Prerequisite:

You must have the following tools:

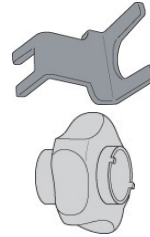

- an Allen key
- an adjustable wrench



From the work screen of your edger, select  >  >  to change or clean the drill bit.

- 1 Select the diameter of the drill bit to install (0.8 mm or 1.0 mm).
For cleaning, select the diameter of the drill bit in place.



- 2 Select the type of operation:
 -  Installing a new drill bit: at the end of the procedure, the wear statistics will be reset to zero.
 -  Replacing the drill bit with a different diameter bit or cleaning the bit in place: the wear statistics will not be reset.
- 3 Select the diameter of the drill bit to insert (0.8 mm or 1.0 mm).



- 4 Press .
 - > The GMD module moves to facilitate the operation.
- 5 Hold the shaft with the Allen key.

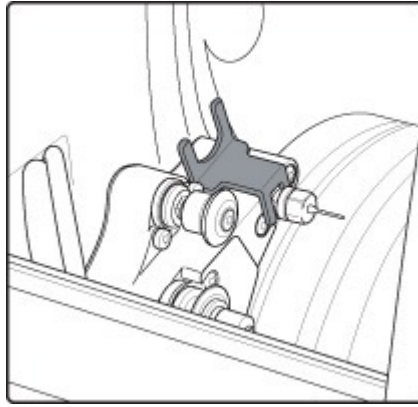

- 6 Put the adjustable wrench on the chuck



The adjustable wrench must never touch the drill bit.

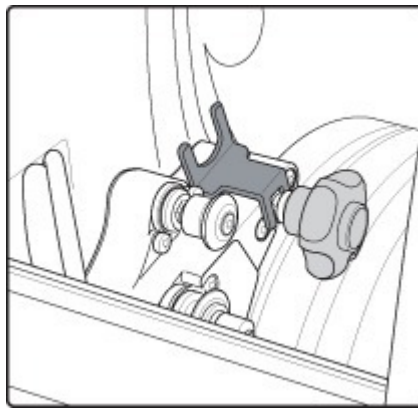

- 7 Loosen the chuck with the adjustable wrench (two notches towards yourself).

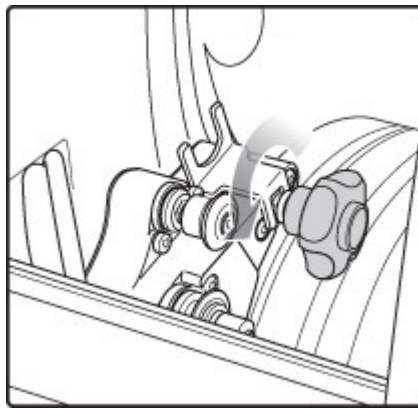

- 8 Remove the adjustable wrench then the drill bit.

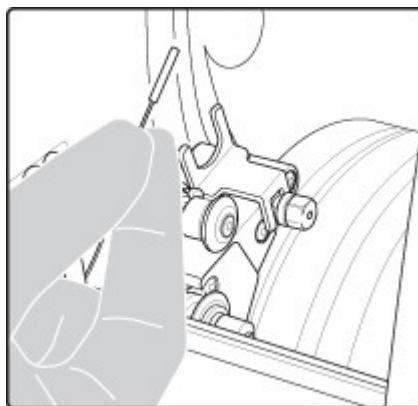

- 9 Insert the new drill bit all the way, then tighten the chuck firmly by hand.

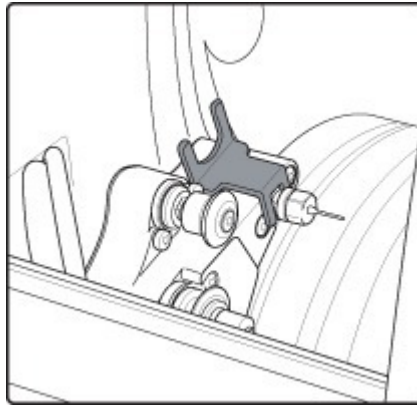

- 10 Remove the Allen key, in order to not lock up the mechanism.

- 11 Press .

> The module goes back into its initial position.

c. Changing the engraving tip

From the edger work screen, select  >  >  to change or clean the engraving tip.



The wear indicator tells you when you need to change the engraving tip after every 50,000 mm (5 km).



When an engraving is uneven, you may need to change the engraving tip: refer to your customer service technician.

Prerequisite:

You must have the following tools:

- an engraving tip
- an Allen key
- an adjustable wrench

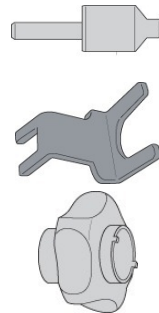

The engraving tip should only be in the edger when engraving cycles are being performed.
The chuck must always contain a tool to avoid any risk of oxidation.



You must replace the engraving tip with the drill bit as soon as you go back to the edging menu.
An alarm indicates that:



-  Hold the shaft with the Allen key.

1



2 Put the adjustable wrench on the chuck



The adjustable wrench must never touch the engraving tip or with the drill bit.

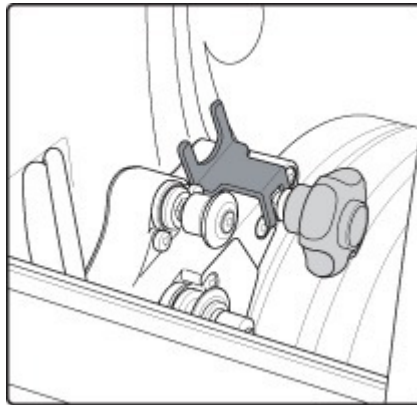

3 Loosen the chuck with the adjustable wrench (two notches towards yourself).

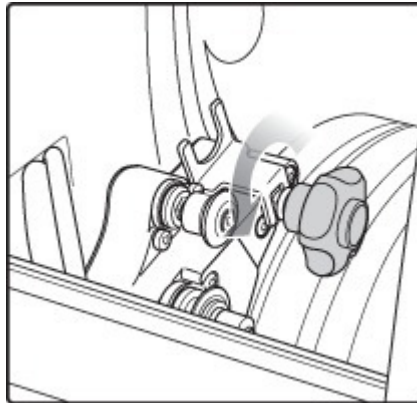

4 Remove the adjustable wrench then the drill bit.

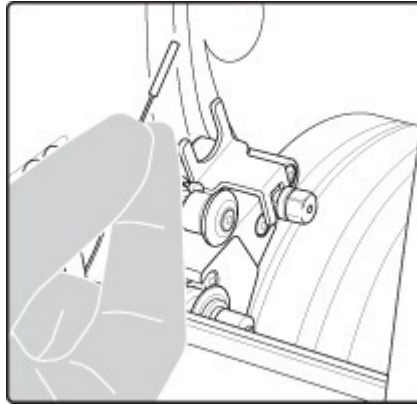

- 5 Insert the engraving tip all the way, then tighten the chuck firmly by hand.

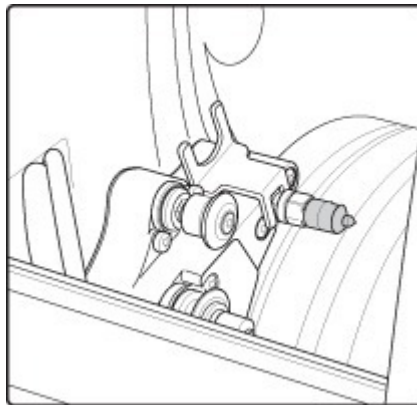

- 6 Remove the Allen key, in order to not lock up the mechanism.

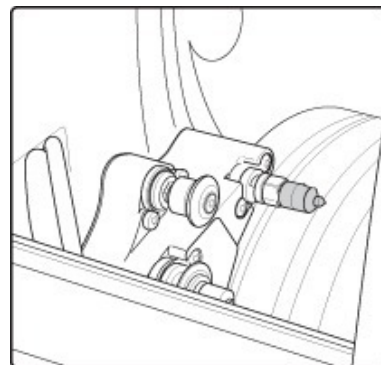



5. Statistics and technical log

This menu enables you to visualize the number of cycles performed by the edger. It also gives you access to the technical history.

- Edger cycles (p.88)
- Technical history and errors (p.90)

a. Edger cycles

From the work screen, select  >  >  to view the number of cycles carried out by the edger.

The following screen is displayed:

General statistics_ Drilling statistics



1. Partial counter

The replacement of a worn tool with a new one resets the partial counter(s) to zero.

2. Total counter

3. Edging operations

Number of edging, drilling and finishing operations performed depending on the lens material:

- Roughing
- Milling
- Bevels
- Flat-edge finish
- Grooves
- Drill-holes/slots
- Notches
- Polishing
- Chamfers
- High-base bevels
- Engravings

4. Drilling

Number of drilling operations performed for each lens material, according to the drill bit used.

5. Touch screen calibrations

6. Dressing cycles

Glass roughing wheel/Finishing wheel/Polishing wheel

7. Number of lenses cut

8. Next page/Previous page

Creative shapes statistics_ Engraving statistics

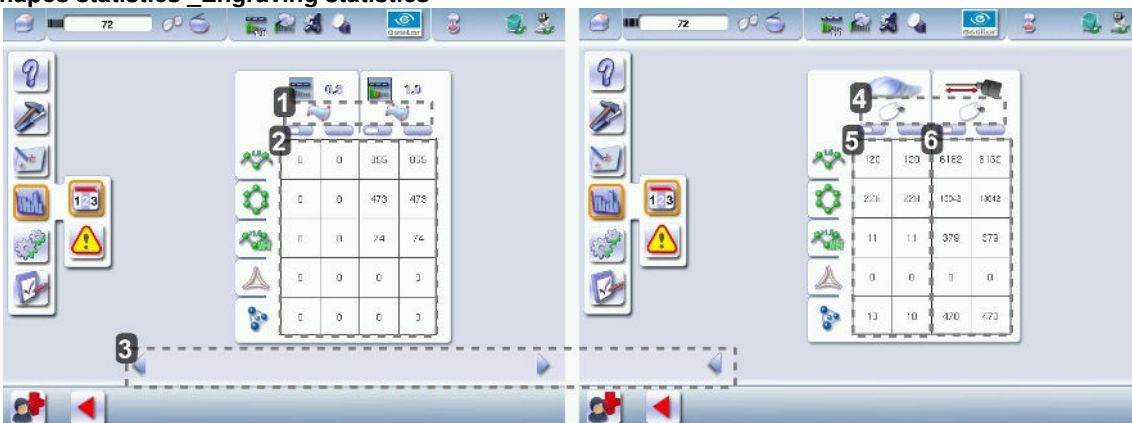

1. Creative shapes

2. The displayed values correspond to the cutting length (in mm) per material according to the drill bit
 - drill bit 0.8 mm,
 - 1 mm drill bit.
3. Next page/Previous page
4. Engravings
5. Number of engraved lenses per material (retouches included)
6. The displayed values correspond to the total engraved length (in mm) per material.

b. Technical history and errors

In the work screen of your tracer or edger, select  >  >  to access the list of error messages. The following screen is displayed:

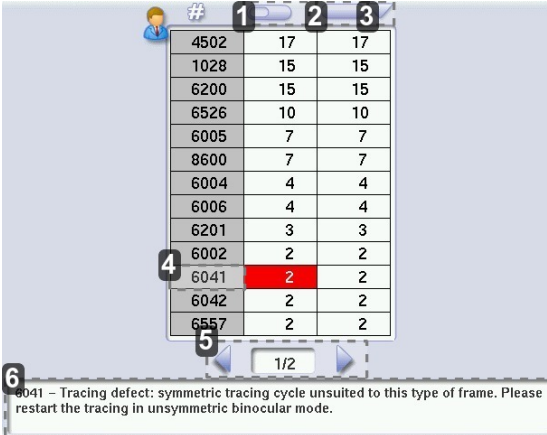

4502	17	17
1028	15	15
6200	15	15
6526	10	10
6005	7	7
8600	7	7
6004	4	4
6006	4	4
6201	3	3
6002	2	2
6041	2	2
6042	2	2
6557	2	2

6041 - Tracing defect: symmetric tracing cycle unsuited to this type of frame. Please restart the tracing in unsymmetric binocular mode.

1. Partial counter



Number of error messages displayed since the last reset to zero.

You can sort the error codes generated by the machine by frequency of appearance.

Sorting is applied to the partial counters by pressing  , a second button  is used to define the direction of the sorting (ascending, descending).

2. Total counter

You can sort the error codes generated by the machine by frequency of appearance.

Sorting is applied to the total counters by pressing  , a second button  is used to define the direction of the sorting (ascending, descending).

3. Sorting

Button used to define the direction of sorting (ascending, descending).

4. Error message codes

Classed by display frequency.

5. Error message pages

6. Description of selected error

Use the scroll box on the right of the message box to scroll through the text.

Press  to go back to the work screen.

6. Maintaining and cleaning the edger

This section describes the maintenance and cleaning procedures for the edger:

- Precautions required (p.90)
- Clean the door, the GMD module and the wheels (high-base and step bevel) (p.91)
- Dress the wheels (p.91)

a. Precautions required



To avoid any incidents, unplug the device before all cleaning operation.

- Clean the edger covers regularly: use a neutral detergent (e.g. washing-up liquid) diluted with water on a soft cloth.
- Clean the touch screen with a dry rag: it should never come into contact with liquid (e.g. water, alcohol, window cleaner).
- Service the water recovery and filtration systems regularly.
- Use the protective covers on the machine to keep it dust free: dust detracts from the precision and operation of the machine.



- Never clean the machine with chemical products (e.g.: petrol, thinners, solvents).
- Never clean the machine elements (module, etc.) with a wet rag.
- No additive should be added to the water in the edger tank. Do not add pyridine.

b. Clean the door, the GMD module and the wheels (high-base and step bevel)

From the work screen of the edger, select  >  >  to access the cleaning menu.

The following screen is displayed:

Cleaning the door and GMD module

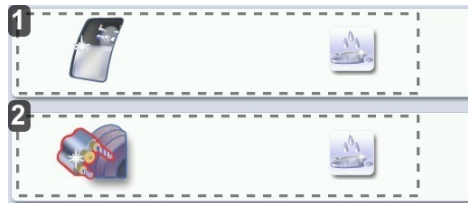

1. Cleaning the door

1. Press  to start the door cleaning cycle.
The module moves to facilitate the cleaning.
> The door opens.
2. Use a cloth to clean the inside of the door.

2. Cleaning the module and trough

- Press  to start the cleaning cycle.
- > The door closes.
 - > The cleaning is done automatically.

Clean the high-base and step bevel wheels

Once the wheels are disassembled, use white vinegar anti-scale solution to clean them.



Cleaning the wheels must be performed only when the wheels have been disassembled and **are outside the trough**.

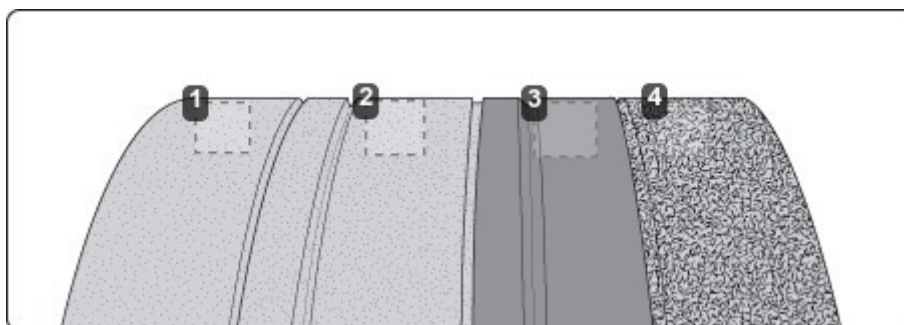

c. Dressing the wheels



1. Glass roughing wheel

2. *Finishing wheel*
3. *Polishing wheel*
4. *Plastic roughing wheel*

This wheel cannot be dressed

On the edger work screen, select  >  >  to access the wheel dressing menu.



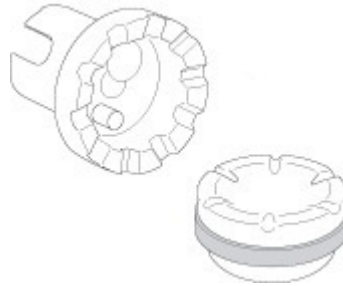

You can access the dressing menu by pressing  in the work screen.

- 1 Make sure that the 22 mm accessories (posiblock holder and stop) are installed on the lens clamp shafts.





- 2 Select the appropriate dressing cycle:



-  Glass roughing wheel
-  Finishing wheel
-  Polishing wheel



Never dress the polishing wheel twice in a row to avoid possible damage.

> For each wheel, there is a specific dressing stone, whose icon is displayed on the screen:

- The orange dressing stone  for the glass roughing wheel
- The white dressing stone  for the finishing wheel
- The square dressing stone  for the polishing wheel

- 3 Insert the dressing stone for the selected cycle between the lens clamp shafts, with the hollow side against the posiblock holder.
- 4 Press  to close the clamps.
- 5 Press  to start the dressing cycle.
- 6 Once the cycle is finished, press  to open the clamps and remove the dressing stone.
- 7 If the dressing stone shows a residual ring, remove it in order not to disrupt subsequent dressing operations.

V. USING TO M' EYE SIGN

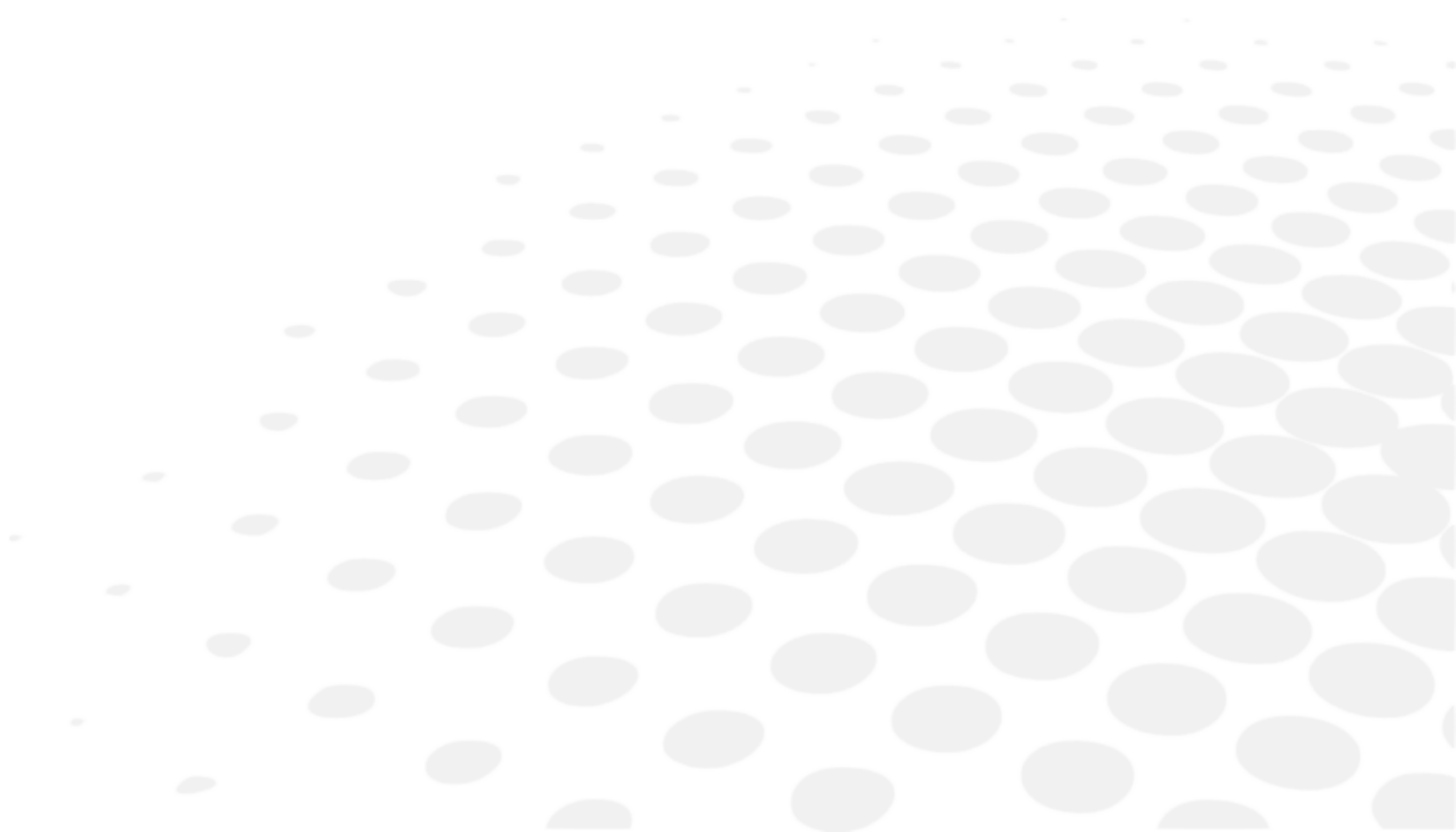

This section describes the procedures relating to:

- activation of M'EYE Sign function (p.95),
- carrying out an engraving, (p.97)
- carrying out a creative shape (MEye Touch). (p.97)



For engraving function training, a tutorial is available on the "MEYE Sign" USB key, which is in the box.

✓ Necessary tools before using M'EYE Sign:

1. a Mr. Blue 2.0 chain (V8.1 recommended),
2. Essibox:
 - equipped with the 5.1 (minimum) memory version,
 - with "Centered Essibox" setup.

1. To activate to M'EYE Sign



✓ Prerequisites for M'EYE Sign activation:

1. a Essibox:
 - equipped with the 5.1 (minimum) memory version,
 - connected to the internet and registered under the client (SIS).
2. a Mr. Blue 2.0 chain connected and installed on Essibox,

On Essibox

- 1 Make sure you have the M'EYE Sign license number available in the box.



- 2 Click on the flag (for example ) to go back to the *Settings* menu.
- 3 Press  on the M'EYE Sign line.

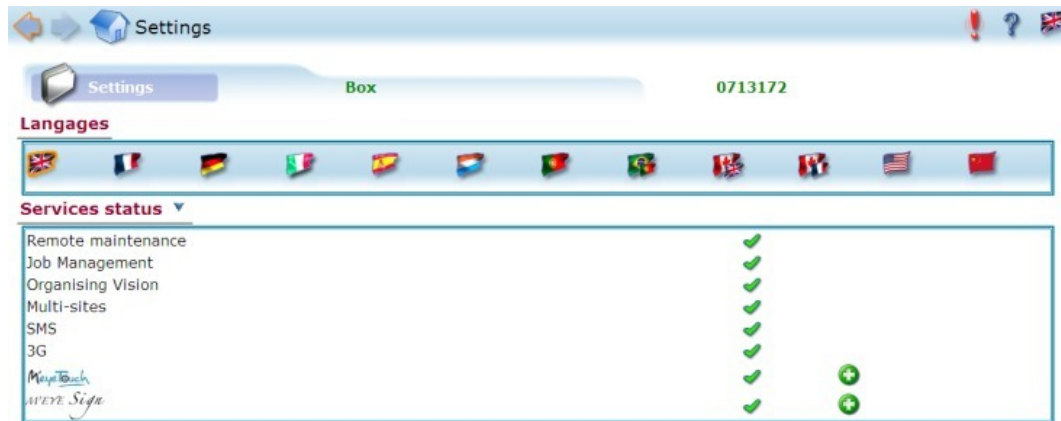

> The screen for inputting the license number is displayed:



4 Enter the license number and press  to confirm.

> The general terms and conditions are displayed.

5 Read the terms and conditions, then tick the box "I accept..."



> The M'EYE Sign function has been activated.



In some cases, the installment of the function may take up to 15 mins.

> The "Job management" menu symbol changes: 

> In job management:

- the engraving menu  is displayed,
- the M'EYE Touch "creative distortion"  is displayed.

> The M'EYE Sign menu is displayed on the Mr. Blue edger.

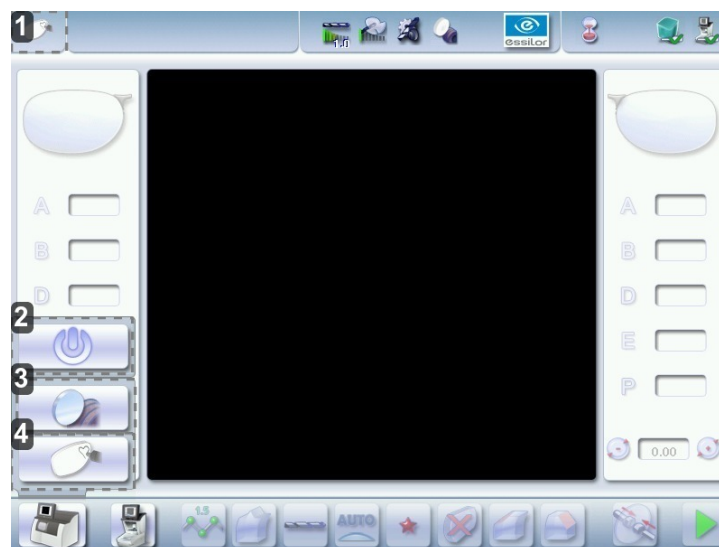

1. Indicator of the engraving screen
2. Edger Power On/Off
3. Edging menu

4. Engraving/Me EYE Sign Menu

> The *Options* screen is displayed:

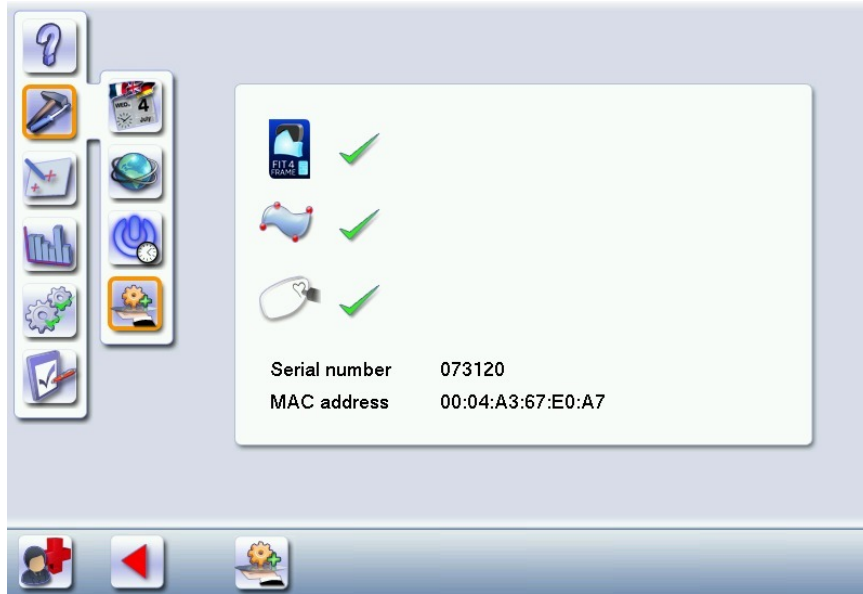

On trade show sales PC(s) (the Essibox link has been added to the favorites)

1 Open the Google Chrome browser .



First check that the PC(s) is/are on the same network as Essibox.

2 Type "http://essibox_server" (or the Essibox IP address, which you will find on the "Identity" page) into the address bar, then press enter.

3 In the address bar, click on the far right end to add the link to Essibox to the favorites bar.



If your browser blocks popups, the symbol is displayed in the address bar, right click on this symbol. A new window opens. Select "authorize the pop window up on this site" and click on OK.

4 Press F5 on your keyboard to refresh your screen.

2. To carry out an engraving

This section describes:

- the choice of engraving and preparation of engraving on Essibox (or on a networked computer), (p.97)
- the completion of the engraving on the Mr. Blue 2.0 edger, (p.107)
- setting up favorites. (p.111)

a. To prepare the engraving

The preparation of engraving is carried out on Essibox (or a networked computer) in two stages:

1. choosing the motif, (p.97)
2. setting up the engraving (p.104)

Choosing the motif

Various work options are possible, you can:

- choose a motif to be engraved without prior job and shape preparation.
>This option lets you save a selection of motifs simply and quickly for engraving later.
- choose a motif to be engraved after having prepared the job and the shape.

>This option allows you to show the customer the position and the size of engraving on the shape.

Menu screen

Choice of motif

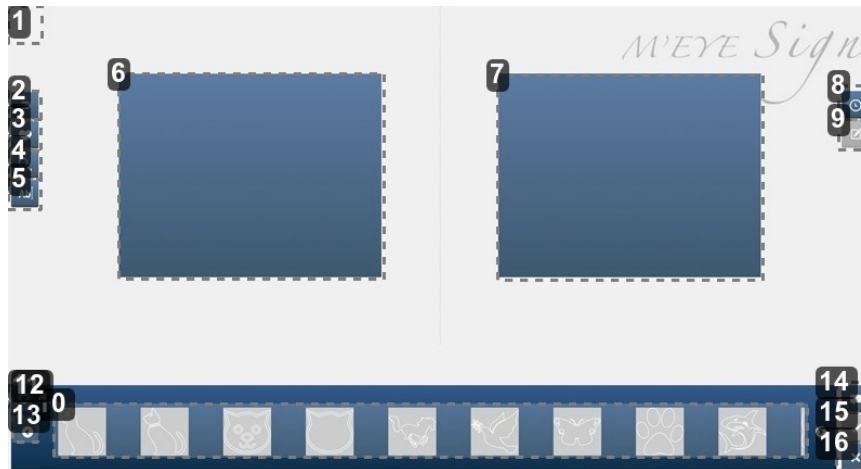

1. Current job number

If you return to the engraving menu without selecting a job, no number is shown.

2. Choice of a category

- Animals
- Stars
- Celebration
- Cultures and communities
- Flowers and plants
- Fun and children
- Games
- Music
- Peace and Love
- Sports
- Symbols
- Transport
- Tribal
- Zodiac signs

3. Choice from favourites

See the next paragraph for a description of the favourites bar.

4. Search by keyword

5. Choice of letters or symbols

Gives access to the text entry field and choice of font.

6. Right side

7. Left side

8. List of engravings on hold

Allows the workshop to search for a selection of engravings made at the time of the sale, in order to associate it with the job to be done.

9. Configuration of engravings on shapes

Function only available if a job containing a shape was selected before accessing the engraving menu (see the paragraph "Screen for configuration of engravings on shapes").

10. Motif view bar

If a category is selected, its name is displayed at the top of the bar. Here, no category is selected.

11. Activation or deactivation of the Add/Delete favourites bar

12. Add favourites

Becomes  when the view bar displays favourites to allow you to delete them.

13. Browsing the motif view bar

14. Comments intended for the workshop

Allows entry of a comment. The icon is displayed in green when there is a comment to read.

15. Save

Allows you to save the customer's choice from the list of engravings in the queue so that the workshop can find it and link it to the assembly. By clicking on it, the window for entering the customer's first name and surname is displayed.

16. Exit the screen without saving

1st work option: To choose a motif without first selecting a Job



You can access the engraving menu without selecting a job from the list. By doing so you can save a simple selection of motifs, under the customer's name, while waiting for job preparation.

1 Press  to start "Job Management."

2 Press  to access the engraving menu.

> Motif choices are displayed on the screen:

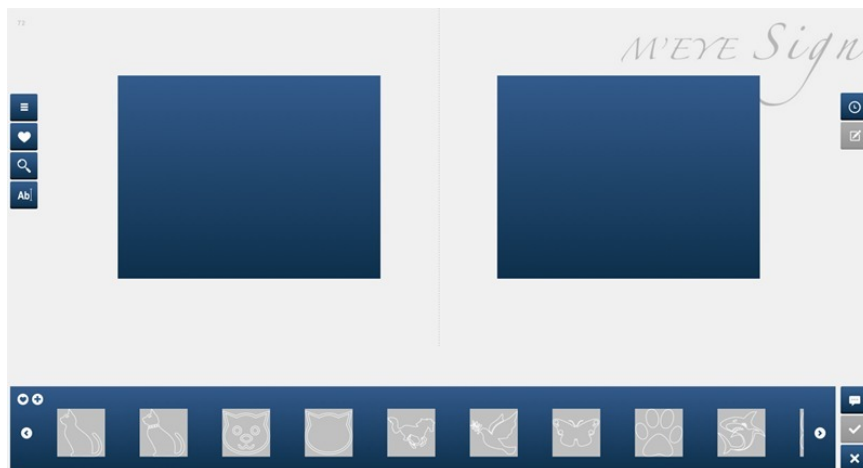

3 Select the motif from the display bar, then drag-and-drop it onto the side of the lens.



To delete a motif, drag-and-drop the motif out of the frame.



You can setup your favorites, refer to the section setting up favorites (p.111).



You can engrave different motifs on the right and left lens.

In the case of a text motif:

Press  to enter your text (e.g. initials, first name, etc.) and choose your font.

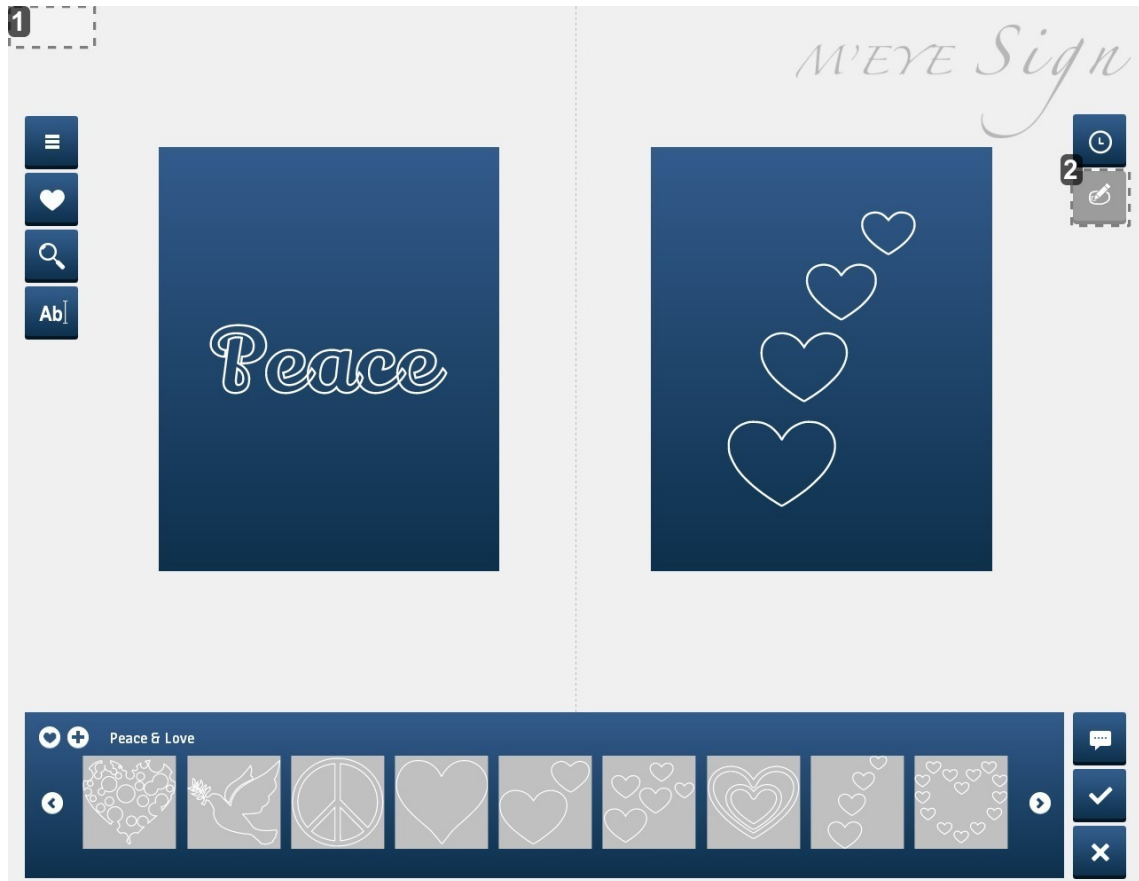

1. Lack of job number
2. Setup screen inaccessible







4 Press  to enter a comment for the workshop

> The symbol is displayed in green  when there is a comment to be read.

5 Press  to save the motif selection.

> The screen below appears:



PUT ON HOLD

LAST NAME	FIRST NAME	RIGHT MOTIF	LEFT MOTIF
			
			 

1. Name
2. First name:
3. Right side motif
4. Left side motif
5. Confirm
6. Cancel

- 6 Enter the first and last name of the customer for whom the job or the selection of motifs is intended, then press  to confirm.
- > The motifs have been saved.

To connect the motif selection with a shape.

- 1 Press  to start "Job Management."
- 2 Select the job that you want to assign a selection of motifs to for engraving and press  to access the *engraving* menu.
- 3 Press  to check engravings in the queue (selections of engravings saved under the customers' names).
- > The following screen will appear:

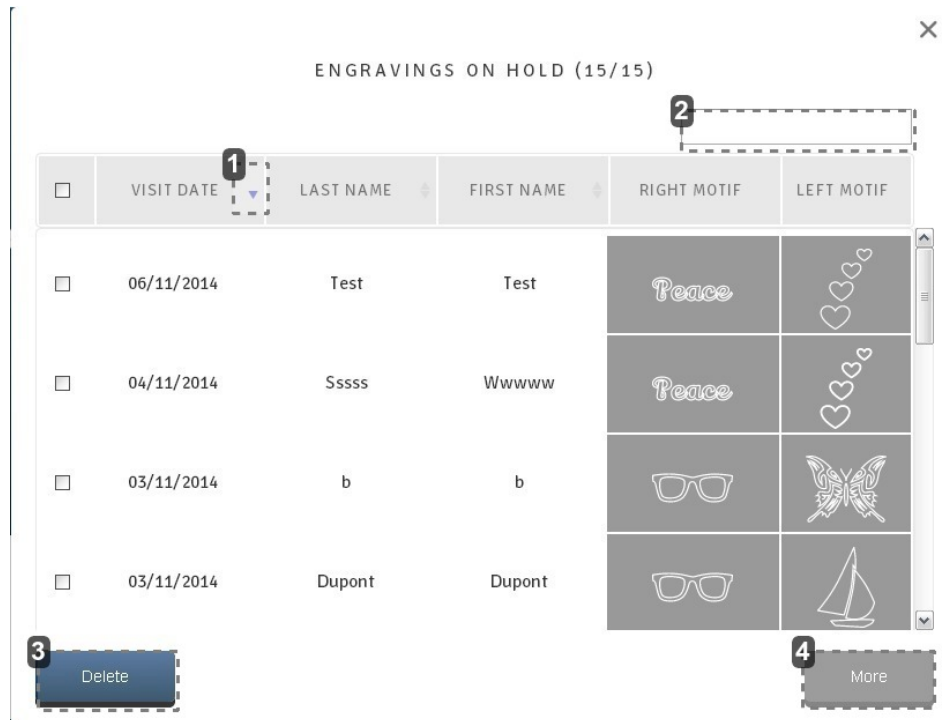

1. *Sorting*
It is possible to sort each column.
2. *Search*
Enter your search criteria.
3. *To erase*
Select the motifs to be removed by ticking the boxes then press *Delete*
4. *More*
To display a more significant number of engravings in the queue.

- 4 Double click on the chosen motif selection.

> The following screen will appear:

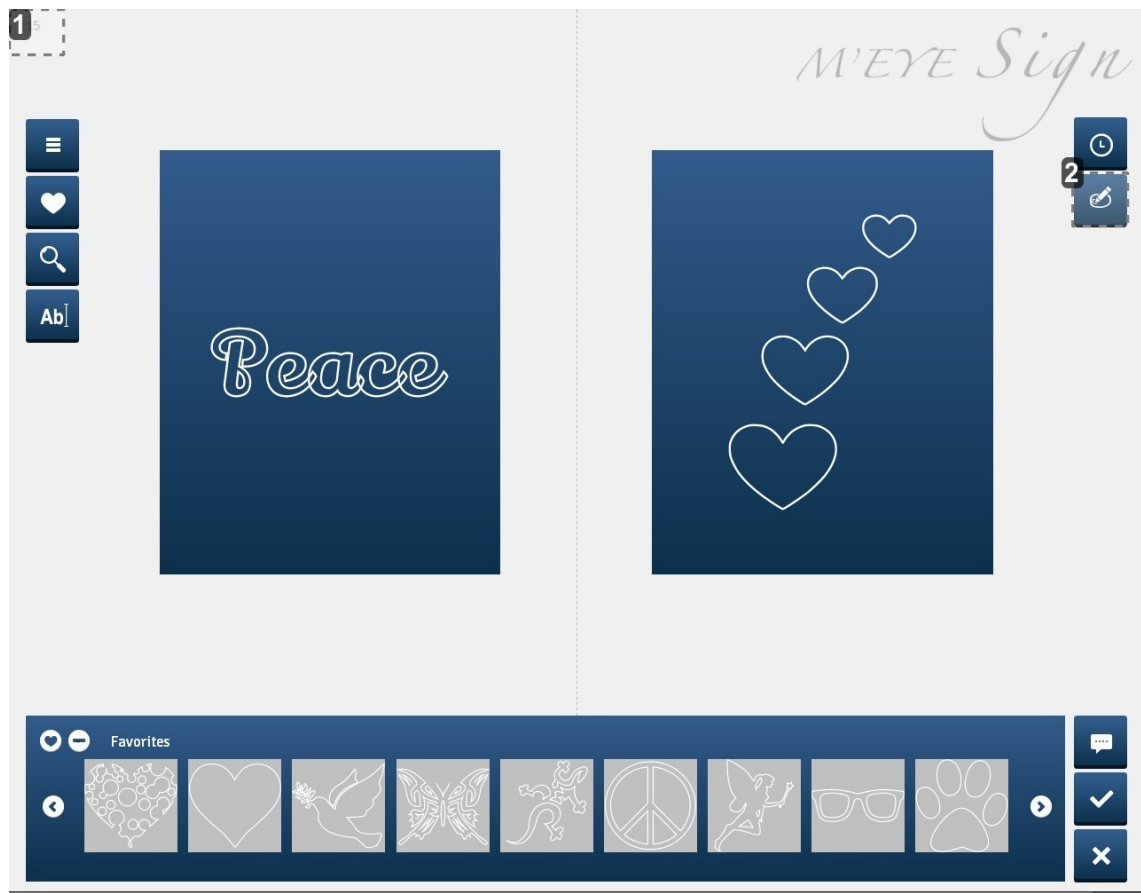

1. Job number
2. Accessible settings screen

5 Press  to set up the engraving

2nd work option: Choosing a motif after having selected a Job beforehand

1 Press  to start "Job Management".

> The screen below is displayed:

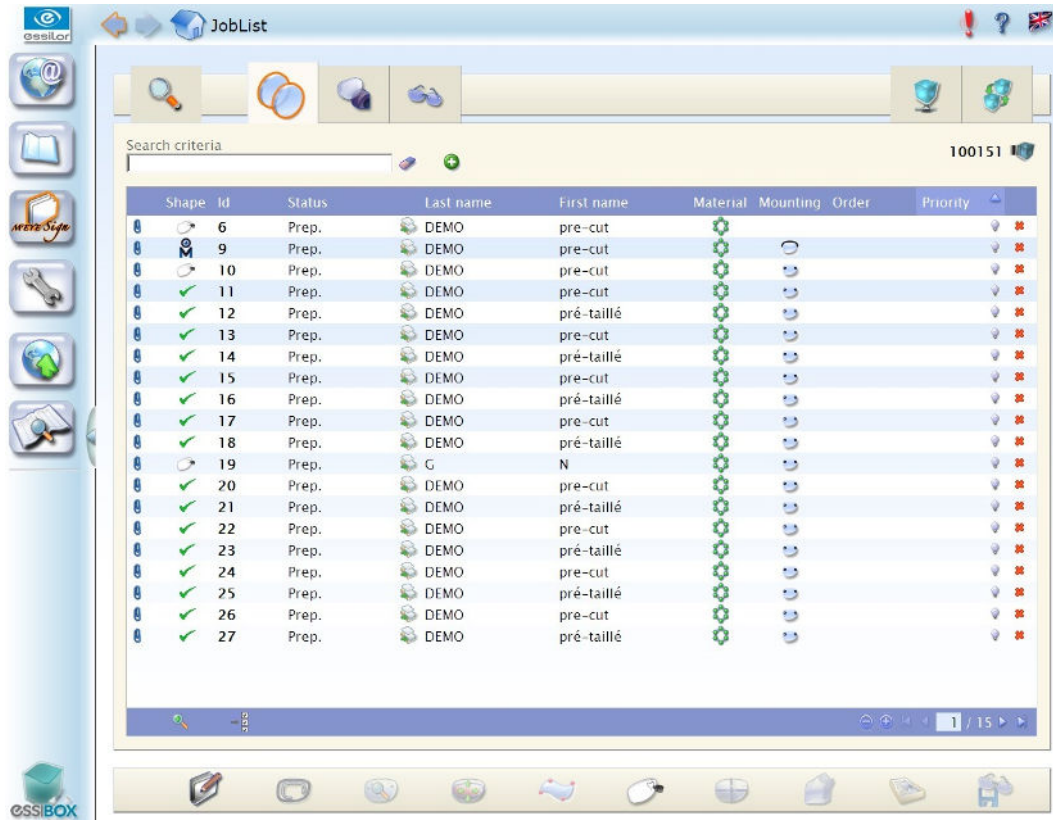

Shape	Id	Status	Last name	First name	Material	Mounting	Order	Priority
6		Prep.	DEMO	pre-cut				
9		Prep.	DEMO	pre-cut				
10		Prep.	DEMO	pre-cut				
11		Prep.	DEMO	pre-cut				
12		Prep.	DEMO	pré-taillé				
13		Prep.	DEMO	pre-cut				
14		Prep.	DEMO	pré-taillé				
15		Prep.	DEMO	pre-cut				
16		Prep.	DEMO	pré-taillé				
17		Prep.	DEMO	pre-cut				
18		Prep.	DEMO	pré-taillé				
19		Prep.	G	N				
20		Prep.	DEMO	pre-cut				
21		Prep.	DEMO	pré-taillé				
22		Prep.	DEMO	pre-cut				
23		Prep.	DEMO	pré-taillé				
24		Prep.	DEMO	pre-cut				
25		Prep.	DEMO	pré-taillé				
26		Prep.	DEMO	pre-cut				
27		Prep.	DEMO	pré-taillé				

2 Select the job you wish to carry out an engraving on, then press  to access the engraving menu.



You can access the *engraving* menu without selecting a job in the list.

> You can save a simple selection of motifs, under the name of the customer, while waiting for the job preparation.

> Motif choices are displayed on the screen:

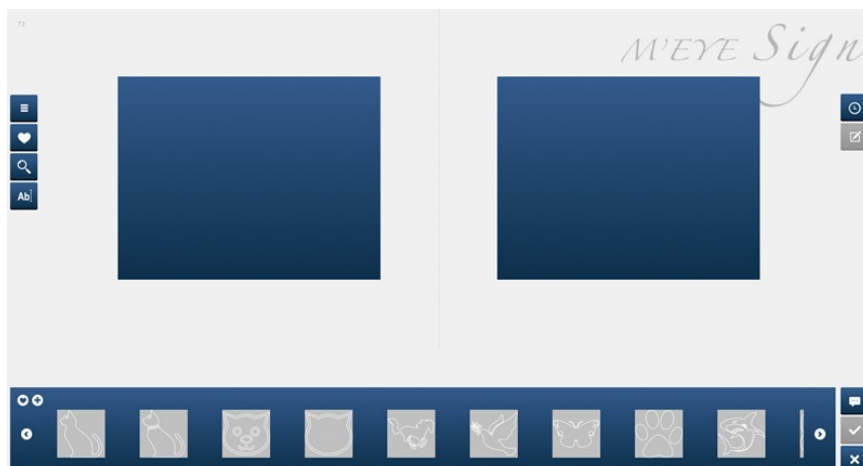

3 Select the motif from the display bar then drag-and-drop onto the side of the lens (for more information, refer to the previous procedure).

4 Press  to set up the engraving

Setting up the engraving

✓ Prerequisite:

You can access this screen if a job containing a shape was selected before entering the M'Eye Sign menu and if at least one engraving has been selected.

The screen allows you to position the motif on the lens shape and adjust its size if necessary.



It is recommended to:

- set up the engraving before centering the lenses (this way, the centering device takes into account the position of the engraving for the choice of the posiblock or).
- carry out all the other shape settings (drillings, shape modifications, etc.) before positioning the engraving.

Menu screen

This screen allows you to adjust the position and the size of the engraving.

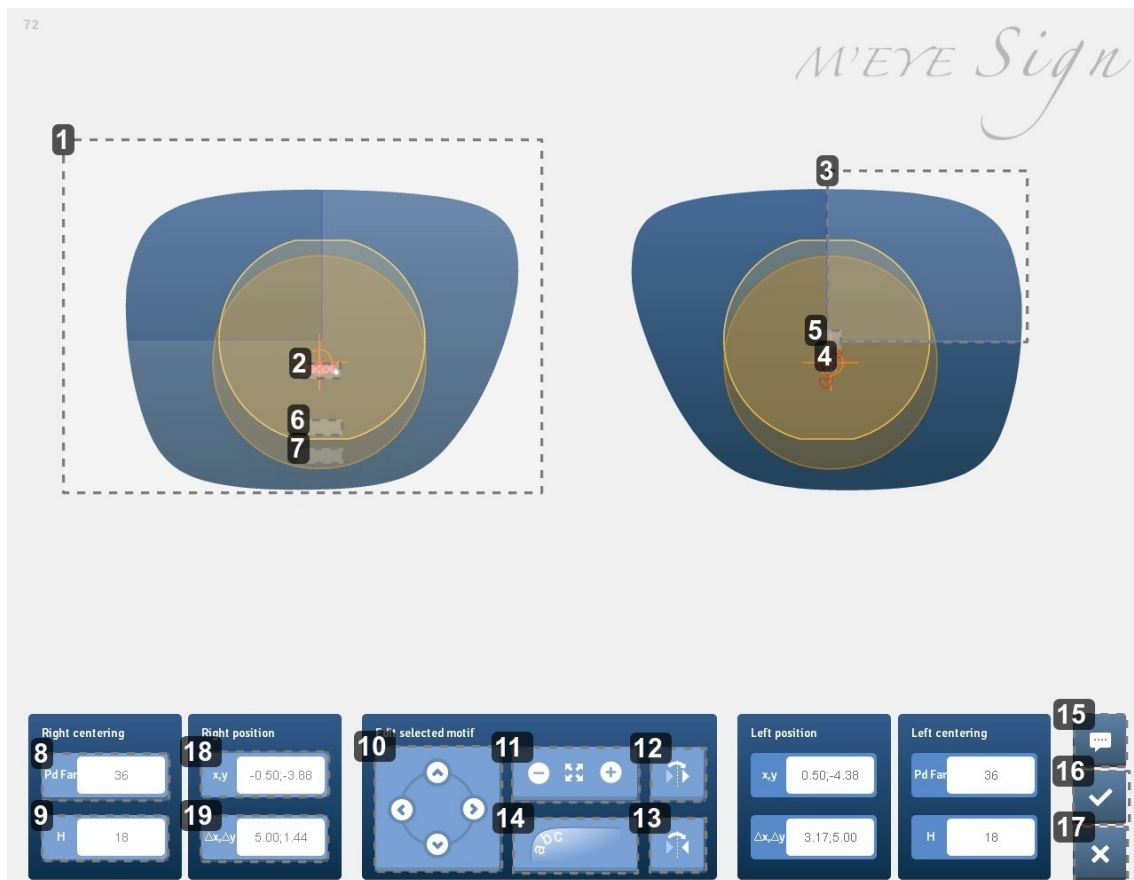

1. Shape of right lens

2. "Peace" motif for engraving on the right lens

The motif is displayed in red when it is incorrectly positioned and therefore not possible. It becomes blue when its position is correct:

3. Frame representing the recommended engraving area

4. Boxing center

5. Optical center

6. Circle representing the "prohibited" area of the edger

This is the area in which the edger cannot engrave.

7. Circle representing the "prohibited" area of the field of vision

The area is centered on the optical center in FV. The half distances and heights must therefore be correctly indicated. If this is not the case, their frame is displayed in red.

8. *1/2 Pupillary distance*

9. *Pupillary height*

10. *Arrows for moving the motif on the shape*

The motif can also be moved with the mouse.

11. *Modification of motif dimensions*

It is possible also to resize the motif with the mouse. Position the mouse on the white mark to vary the size: 

12. *Identical transfer of the selected motif to the other lens*

When the button is active (displayed in dark blue), the modifications made to the selected motif are applied simultaneously to the other motif.

13. *Symmetry of the selected motif with the other lens*

14. *Lens edge tracking*

This function only applies to text motifs.

15. *Green button = comment to be read*

16. *Save*

You access the job management screen again.

17. *Exit without saving*

18. *Position in X and Y of the engraving position*

19. *Engraving size*

The default size is as big as the largest engraving dimension, equal to 5mm.

Procedure

1 Press  to access the engraving settings screen.

> The engraving settings screen appears:

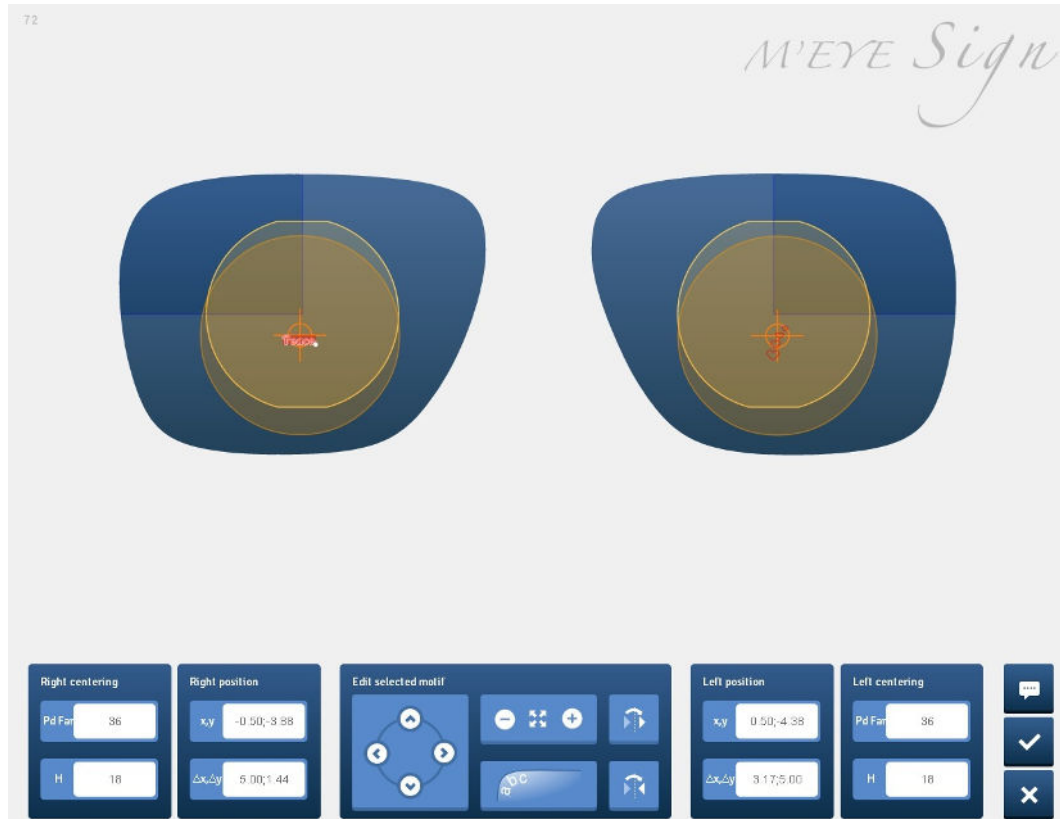





2 Press **Pd VL** to input the 1/2 pupillary distances and press **H** for the heights.



The values are automatically transmitted to the centering device.

3 Press:



-  or  to move the motif towards the right or the left hand side,
-  or  to move the motif upwards or downwards.



You can also move the motif using the mouse.



You can also press:

-  to carry out an identical transfer of the selected motif onto the other lens,
-  to carry out a symmetrical copy of the selected motif onto the other lens.

4 Press  and  to increase or decrease the motif.



You can also resize the motif using the mouse: position the mouse on the  mark and keep the button pressed down to vary the size.



If a text motif is chosen: you have the option of tracking the lens edge.



You must adjust the size of the motif before applying the edge tracking function. Once the function is applied, resizing is no longer possible.

5 Press  to track the lens edge.

> The motif immediately adapts to the edge of the lens.

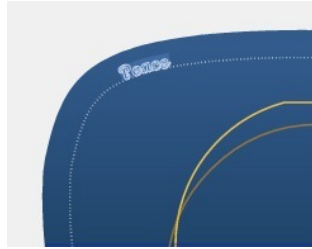

6 Press  or  to move the motif further from or closer to the edge of the lens.



> The dotted marker and the motifs move.

7 Move the motif along the dotted marker via the mouse (holding the click) to position it as required.

> The motif follows the dotted marker.

8 Press  to confirm or press  to leave without saving.



In job management you can assign the Essibox barcode to the prepared job.

b. Performing engraving



You must have performed lens centering and blocking on the tracer before performing edging

1 Call up the job on the edger.

For more information, consult the section Edging a lens > Edger work environment > Calling up a shape (p.21)

> The edging screen is displayed:

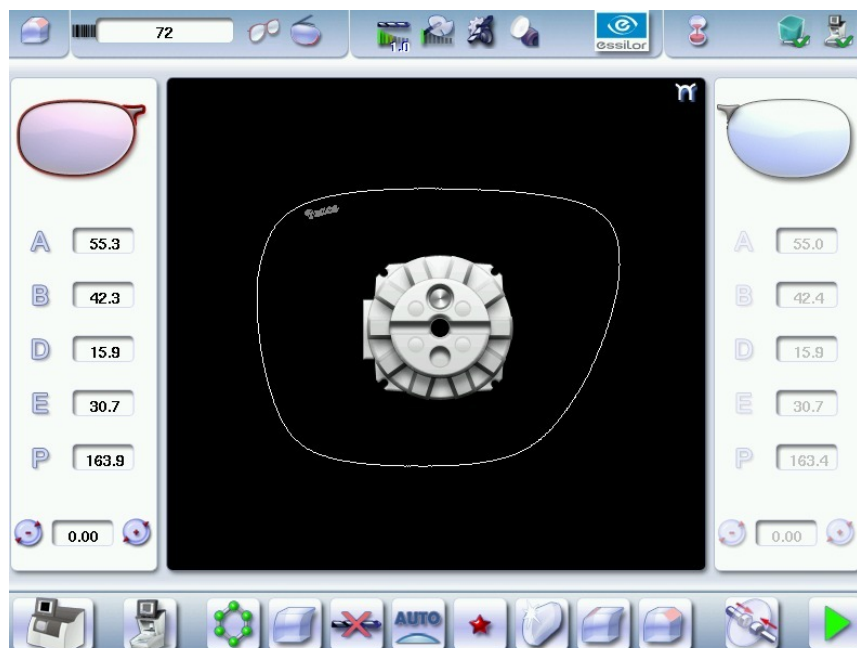

- 2 Set up the edging settings for your job and start the cycle.



For more information, refer to the section Edging a lens. (p.17)

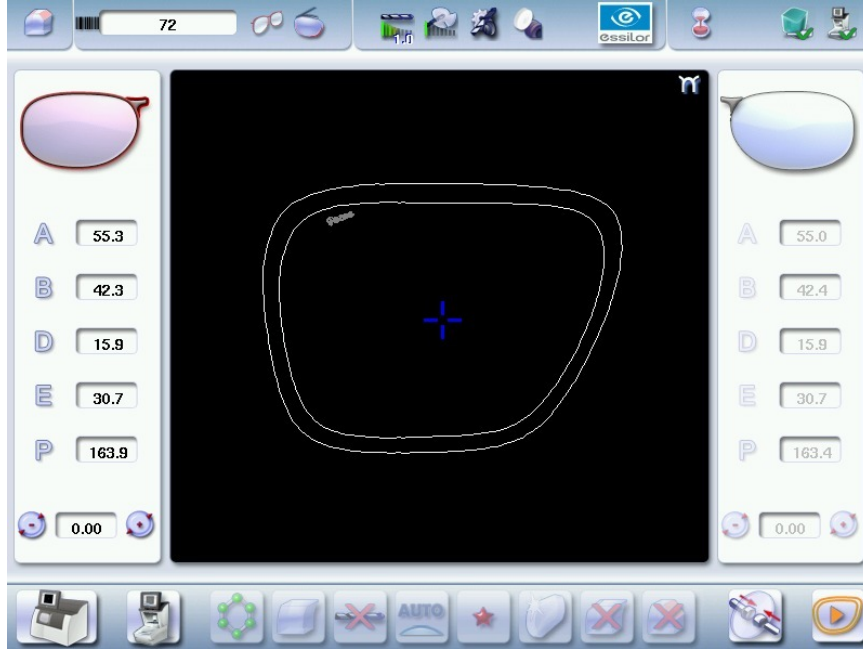

You are not allowed to engrave on glass.

- > Once edging has been carried out, the following screen is displayed:



- 3 Press  then  to access the engraving screen.

- > A window is displayed, which requests you to replace the drilling tool with the engraving tool.



- 4 Change the tool.

For more information, refer to the section Maintenance > Changing or cleaning edger tools > Changing the engraving tip (p. 86)



The engraving tip should only be in the edger when engraving cycles are being performed.
The chuck must always contain a tool to avoid any risk of oxidation.



You must replace the engraving tip with the drill bit as soon as you go back to the edging menu.
An alarm indicates that:



5 Press  to confirm the tool change-over.

> The screen for starting the engraving cycle is displayed:

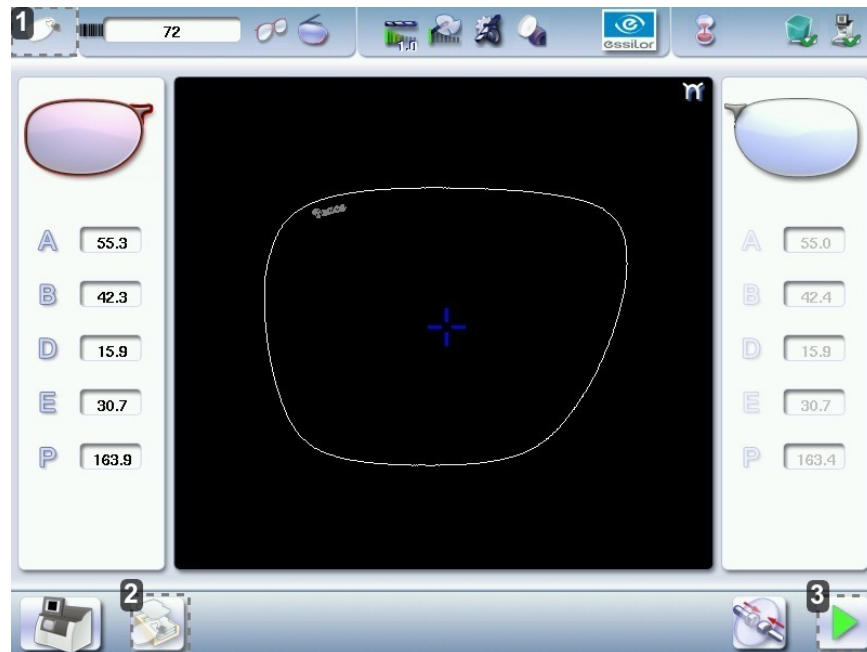

1. Engraving screen indicator

2. Series engraving mode

3. Launching the cycle

6 Press  to start the cycle directly.

7 Press  to use the mode “engravings in series.”



Engraving in series

Perform the lens edging of engraved jobs without carrying out the engravings and keeping the blocked lenses.

At the end of the edging job including engraving, all the necessary information for the engraving is saved (feeling data, jobs, engravings).

You can then call up jobs in order to carry out all engravings one after the other.



The maximum number of jobs saved for the engraving is 500, once the maximum is reached saving a new job leads to removal of the oldest job.





The time lapse between lens edging and engraving should not exceed 2 hours, after this the pad may damage the coating layers applied to the lens.

- > The numeric keypad is displayed.

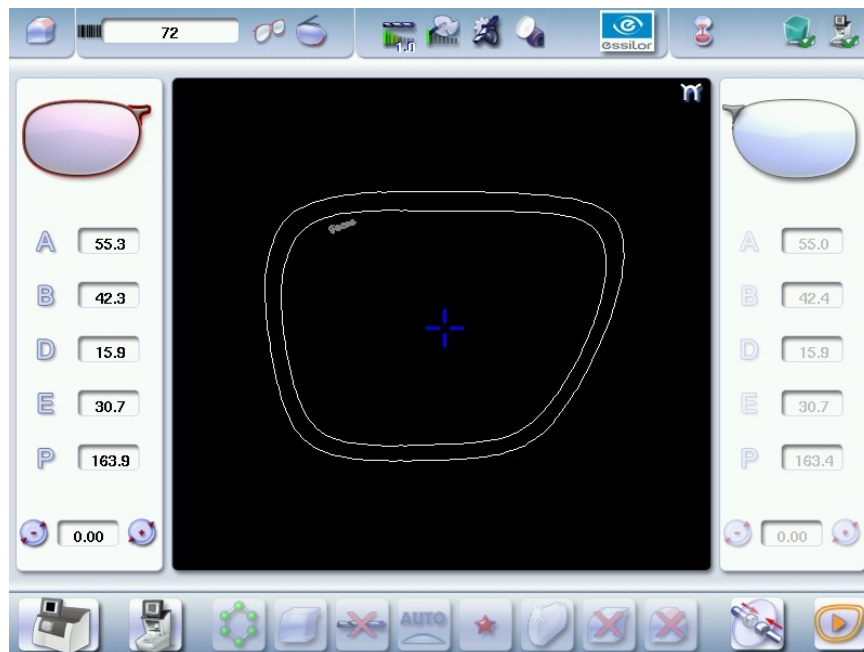

- 8 Enter the number of the job to be engraved.
- 9 Insert the lens to be engraved (already cut and still blocked) corresponding to the selected job.
- 10 Press  for the engraving cycle.
 - > The following screen is displayed:



- 11 You can redo an engraving run by pressing .



It is impossible to start the engraving cycle on the second lens if it has not been cut.
The  button is not available.

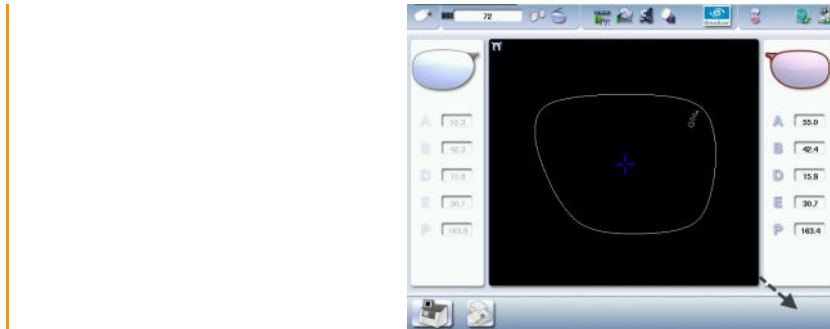

c. Setting up the favorites

Captioned screen



1. Activation or deactivation of the Add/Delete favourites bar
2. Add favourites

Becomes  when the view bar displays favourites to allow you to delete them.

3. Name of the category viewed.
4. Selected motif (gray circle)
 - Click in the circle to select the motif.
 - Click again in the circle to unselect the motif.
5. Motif not selected or unselected (white circle)

Procedure

- 1 Press  to add a motif to your favorites

> The following screen will appear:

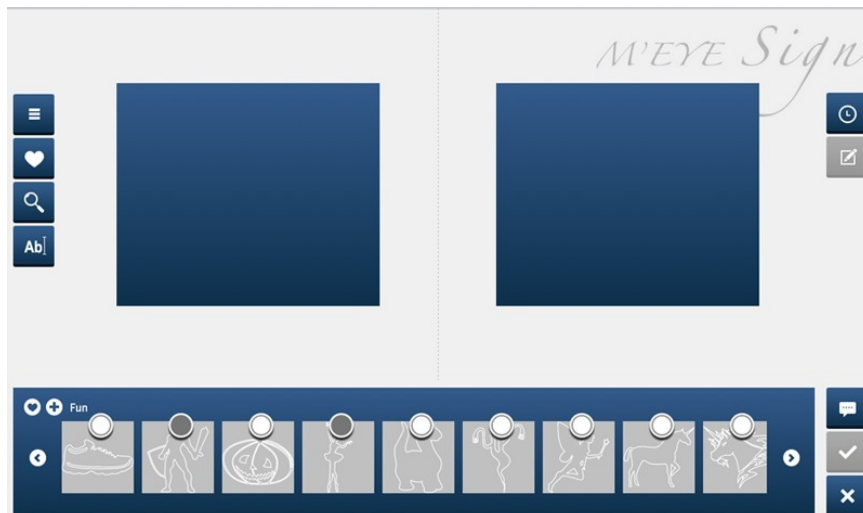

2 Click on  to select the motif.



Click again in the circle to unselect the motif.

> The message "Favorites update" lets you know that the motif has been added to your favorites.

3. To produce a creative shape

To create your own shapes, you can:

- use the pre-cut patterns supplied in the pack and do an optical tracing
- to cut out your own patterns according to your imagination and to carry out an optical tracing (sheets designed for this purpose are provided in the box),
- use the software available on Essibox

For further information, refer to the documentation included on the USB key supplied with your pack, or refer to the Essibox on-line guide.



The user must ensure that the reproduced shapes are not copyrighted.

The optician must inform the patient that wearing lenses with creative shapes must be compatible with the activity of the patient/final customer.











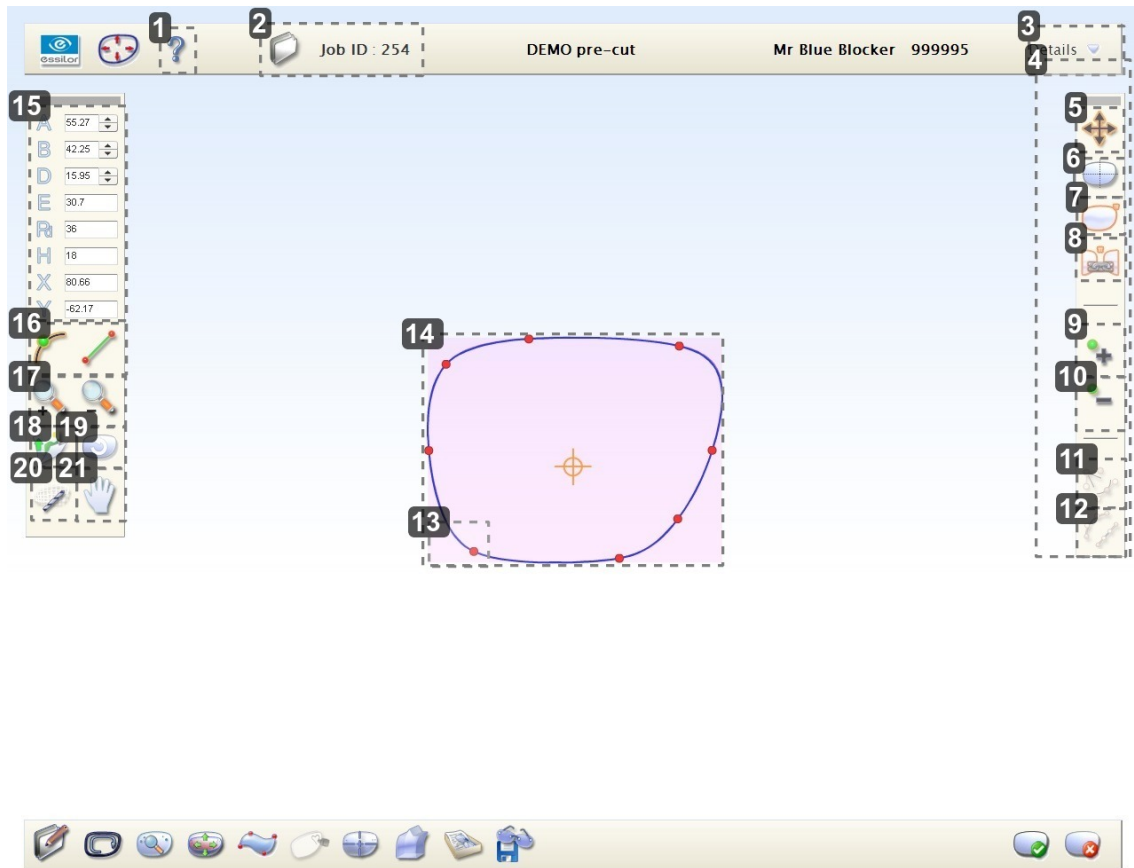



The optician must ensure that wearing the glasses is not harmful to the user.

a. On Essibox

Various work options are possible, you can:

- use the default shape to create your own,
- use any form available in "jobs management" to create the desired form.

Captioned screen

1. Access to online help
2. Job number
3. Information about job
4. tool bar
5. Selection tool
 -  Movement of reference points
 -  Selection of curve and check-points
6. Display mode
 -  To display or mask XY markers.
 -  To display or mask the markings of progressive lenses.
 -  To display or mask the rough lens.
 -  To display or mask the posiblock (after edging simulation).
 -  (nonfunctional)
 -  To display the initial form (before shape modification).
7. Display on the right side
 -  Display on the left side
 -  Display on both sides (in this view, you cannot modify the form).
8. Symmetrical mode
 -  Modification of both sides simultaneously



 Modification of each side separately

>The symmetrical mode is activated by default

9. *To add a reference point*
10. *To remove a reference point*
11. *Tools for modifying "reference points"*

 Angle tool Curved tool

12. *Tools for modifying "segments"*

-  D-segment
-  Curve segment

13. *Reference point*

14. *Shape to be worked on*

15. *Information on the shape*

- A: A-dimension
- B: B-dimension
- D: D-dimension (bridge)
- E: Larger radius from the Boxing center
- Pd: Half pupillary deviation
- H: Pupillary height
- X: Coordinate of the mouse in X in the boxing repository of the lens being worked on
- Y: Coordinate of the mouse in Y in the boxing repository of the lens being worked on

16. *Selection of the modification vector:*

 Reference point Segment

17. *Zoom*

18. *Not available*

19. *Go Back*



20. *Display of the edging screen (simulation)*

This tool allows you:

- to visualize the shape that will be edged,
- to know which tools will be used for edging.



21. *Free displacement*

To use the creative shape modification tool

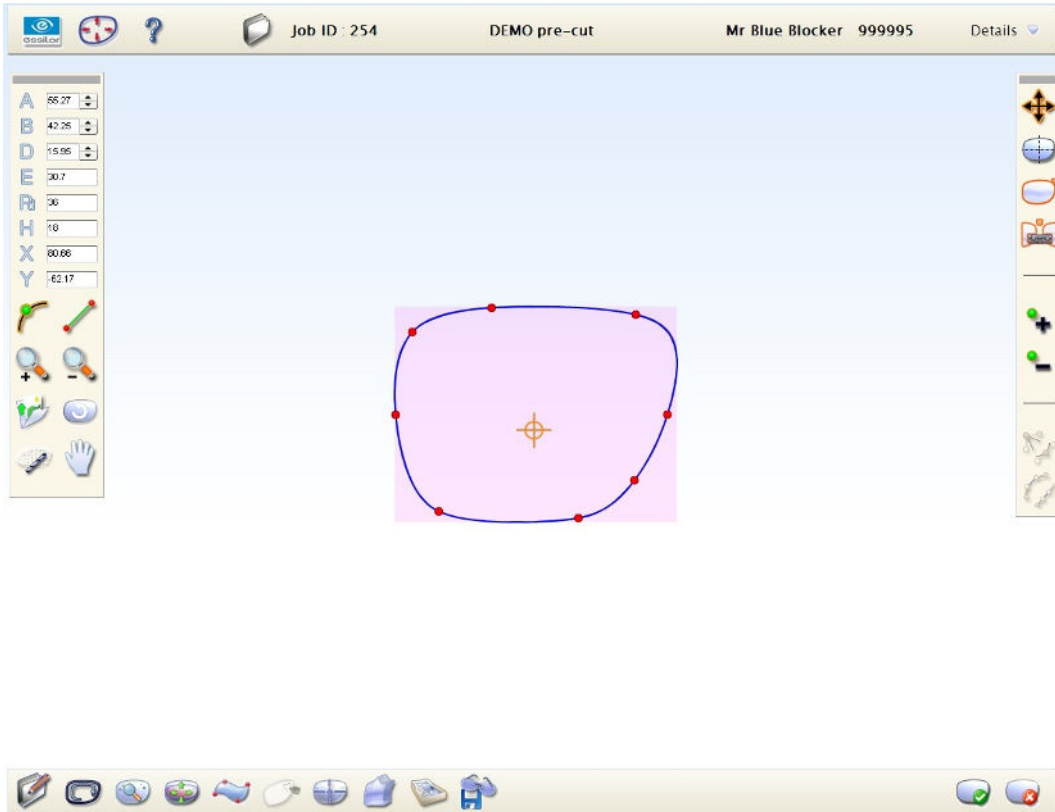

- 1 Press  to start "Job Management".
- 2 Select the job you wish to modify.
- 3 Press  to access "the creative shape modification" menu.

> The following screen will appear:





- 4 Press  to select the point from which you wish to modify the shape
- 5 Press  to select the "angle" tool

> 

- : Reference point: point from which the shape modification will be started.
- : Check-points: points allowing you to modify the curve.

- 6 Press  to add a reference point

 To erase a point, select it with your mouse then press .

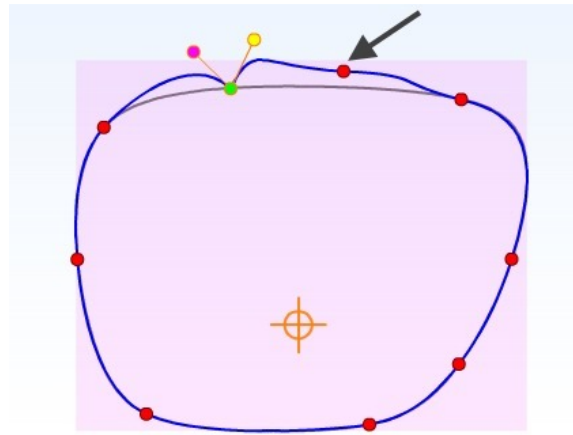

7 Press  to symmetrically modify the segments on both sides of the reference point.

8 Press  to select a segment.

> The following screen is displayed:

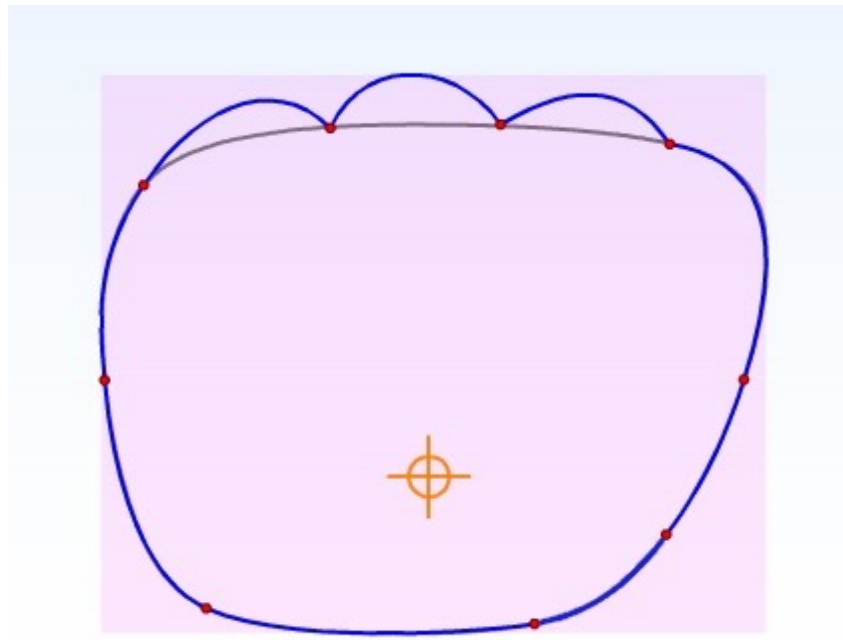

The  menu becomes active.

9 Select the segment to be modified using the mouse.

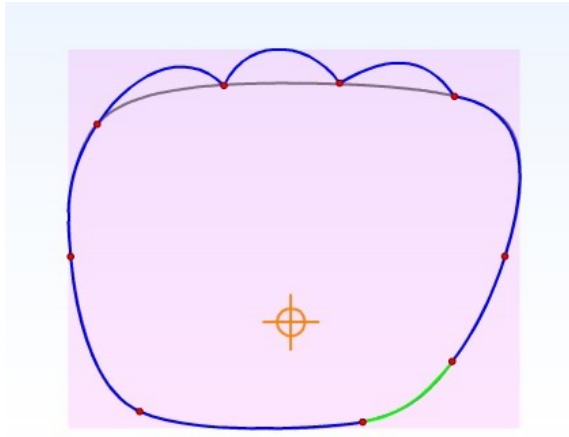

- > The selected segment turns green.

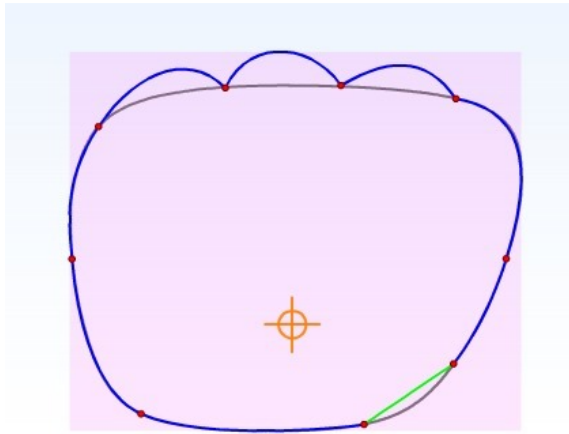

10 Press  to create a straight line.

- > The following screen will appear:





 if you selected , the initial form remains displayed in gray (■).

11 Press  to check workability.

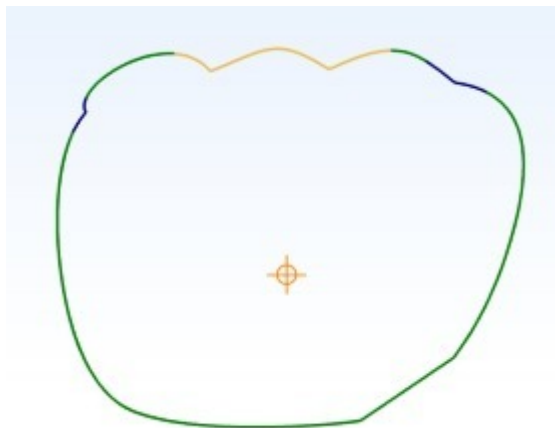
- > The following screen will appear:



-  Large wheels





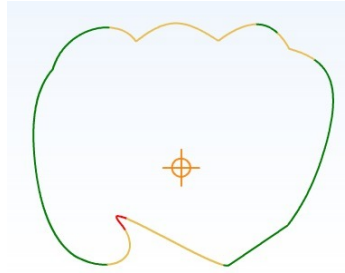

-  Drill bit
-  High-base wheel

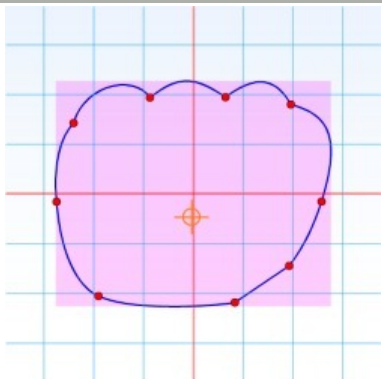

Possible form but in an approximate way in the red sector

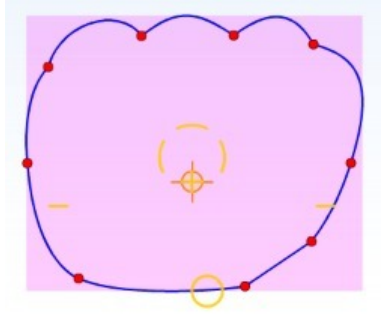

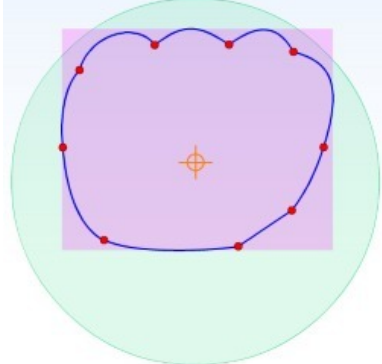
Displaying the markers

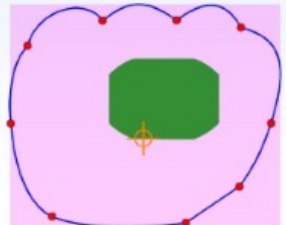

b. On the edger



- If M'Eye Touch is not activated and a negative shape arrives on the edger from the tracer-centerer-blocker, Essibox or a connected software application (PMS, Ophys, VisionWeb, etc.), a warning is displayed:

Press  to confirm.

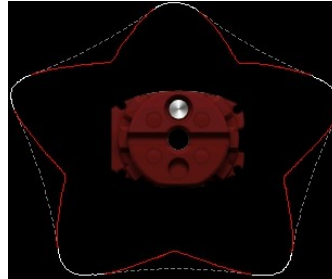
> The following screen is displayed.



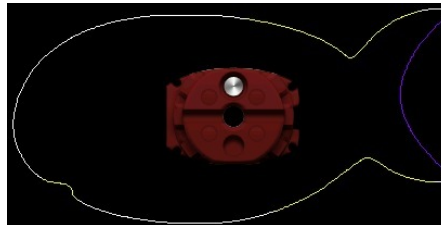

> 2 superimposed shapes appear:

-  Exact outline of the creative shape received
 -  Outline of the shape which the edger can cut with the large wheels
- If M'Eye Touch is enabled, the following screen is displayed:



> The colours symbolise the various tools that will be used to machine the shape:

-  Mill bit for
-  High-base wheel
-  Large wheels

TECHNICAL DATA

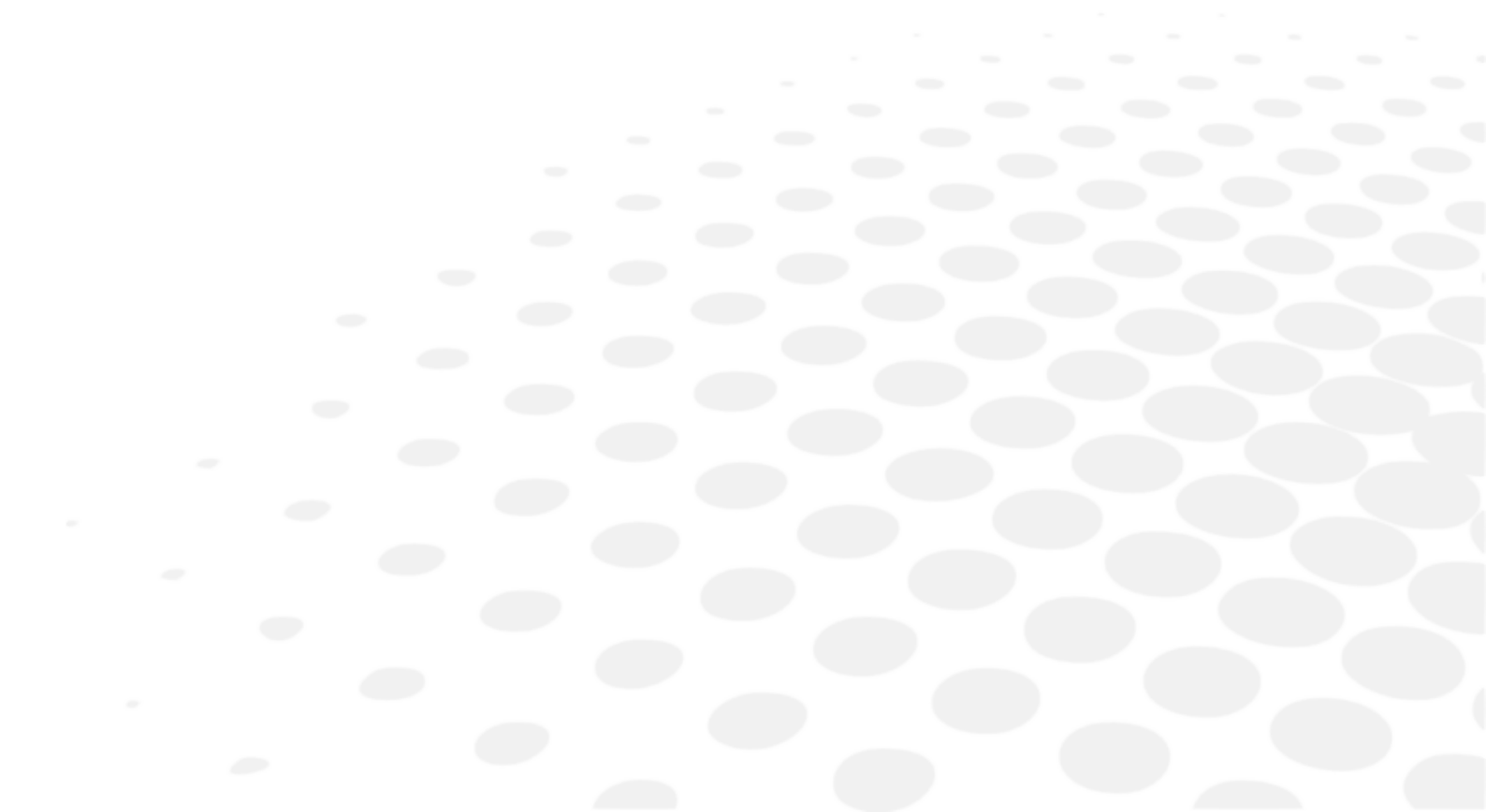

- Machine (p.122)
- Environment (p.123)

Edger

Edger in boxing mode (passive)

Automatic initialization

Tool wear indicators

Simultaneous feeling of the front and rear surfaces of the lens

Types of finish:

- Bevel:
 - Automatic bevel
 - Height of bevel: from 0.3 to 0.75mm.
 - Customized bevel: frame base tracking, rim tracking, distributed bevel (%), front surface tracking, rear surface tracking, partial and global adjustment, displacement
 - Distribution value: modification step of 0.1 mm or 5% (distributed bevel)
- High-base bevel
 - Shelf bevel values: 0.25 to 2 mm; modification step: 0.05 mm
 - Flat side of the bevel value: 0.1 to 1 mm; modification step: 0.1 mm
 - Positioning value of the flat side of the bevel compared to the front surface of the lens: from 0 to 1.3 mm.
- Step bevel
 - Shelf bevel values: 0.25 to 3 mm; modification step: 0.05 mm
 - Flat side of the bevel value: 0.1 to 1 mm; modification step: 0.1 mm
 - Positioning value of the flat side of the bevel compared to the front surface of the lens: from 0 to 1.3 mm.
- Flat-edge
- Grooving:
 - Automatic groove
 - Customized groove: frame base tracking, distributed groove (%), front surface tracking, rear surface tracking, partial and global adjustment, displacement
 - Adjustable groove width and depth
 - Groove depth between 0.20 and 1.20 mm; modification step: 0.05 mm
 - Groove width between 0.60 and 1.20 mm; modification step: 0.05 mm
 - Distribution value: modification step of 0.1 mm or 5% (distributed groove)
- Chamfering:
 - Chamfer adjustable on front surface and rear surfaces
 - Thin chamfering by default: 0.20 mm
 - Thick chamfering by default: 0.40 mm
- Drilling:
 - Automatic adjustment of drilling angle according to lens curve up to 30°; modification step: 0.5°
 - Hole diameter: 0.8 to 3 mm; modification step: 0.05 mm
 - Types of drilling: through-hole, non-through hole, straight or tilted notch, slot and spot-facing
 - Maximum number of drilling points per lens: 20
 - No-drill area: diameter of 27 mm from the boxing center
- Engraving:

All materials except glass. Engraving was initially confirmed on the following lens panel:

 - Essilor Crizal Forte Orma
 - Essilor Crizal Forte PC Plano
 - Essilor Crizal Forte 1.67
 - Essilor Crizal Alize Orma
 - Essilor Crizal Alize 1.67
 - Essilor Trio PC
 - Essilor Supra PC Plano
 - Essilor Crizal Forte Transitions 1.67
 - Strong Essilor Crizal Xperio 1.5
 - Zeiss 1.5 light with Teflon coating
 - Zeiss 1.67 light with Lotutec coating
 - Zeiss 1.67 light with Teflon coating
 - Zeiss Photochromic "Photofusions"
 - Zeiss clear Polycarbonate with Teflon coating
 - Zeiss light varnished Polycarbonate
 - Hoya 1.5 light with Long Life coating

- Hoya 1.5 light with Blue Control coating
- Hoya 1.67 light with Long Life coating
- Hoya PNx light with Long Life coating
- Hoya PNx light with HI Vision coating
- Varnished Hoya PNx light
- Hoya "Suntech" Photochromic 1.67

3-D preview of the bevel and groove before the start of the cycle

Self-learning of work habits

Edging pressure varies according to the material to be edged

Automatic wheel cleaning cycle

Lens edging capacity:

- Max. diameter: 110 mm (90 mm with a decentration of 10 mm)
- Min. B-dimension: 17 mm for flat edge, 18.5 mm for bevel

3 wheel or 4 wheel versions (depending on the material): glass, plastic, polycarbonate, medium or high index and Trivex lensesTM, polishing

Precision adjustment:

- Finished lens diameter of - 2 to + 2 mm
- Drilling diameter of - 0.10 to + 0.10 mm
- Default chamfer of - 0.40 mm to + 0.40 mm
- Default groove:
 - Width of 0.60 to 1.20 mm
 - Depth of 0.60 to 1.20 mm

Networking possibility:

- Tracers-centerers-blockers
- Edgers
- PC
- Essibox

Integrated auto-maintenance functions (self-calibration, autotests)

Size of colour touch screen: 10 inches

Dimensions: L 570, D 490, H 700 mm

Weight: 68 kg

Power supply: 230 V – 50/60 Hz, or 115 V – 50/60 Hz

Power consumption: 1350 W – 10 A for 230 V and 15 A for 115 V

Two-pole circuit-breaker

Average water consumption:

- CR39, glass, TrivexTM and MHI: 8 litres/minute.
- Polycarbonate: 10 litres/minute.

Measured noise level on edging, at a distance of 0.5 m from the machine:

- Plastic lens = 71 dB
- Glass lens = 71 dB
- Polycarbonate lens = 71 dB
- Trivex lensTM = 72 dB
- MHI lens = 71 dB



Due to constant improvements, these specifications may be modified without prior notice.

Environment

Your machine should preferably be installed on a perfectly flat and stable work surface of suitable height (about 70 cm), free from shocks and vibrations, to benefit from the high accuracy of your edger. Your edger can be placed to the right or left of the tracer. However, leave enough space between the two devices for the opening of the side hatches. The tracer may be installed up to 5 m away from the edger (a 5 m cable is supplied with the edger). Longer cables are also available on an optional basis.

The temperature and the humidity of the room where you use your machine must be within the following ranges of values:

Operation:

- temperature between +10 °C and +40 °C
- Humidity: between 30% and 75%

Storage:

- temperature between -5 °C and 50 °C
- Humidity: between 25% and 95%

Altitude: < 2,000 m

Level of pollution: 2

Avoid sudden changes in temperature and humidity and install your system:

- in an area not directly exposed to sunlight
- away from all heat sources
- away from all strong magnetic fields
- away from all chemical products, corrosive vapours and liquids

Take care not to block the vents and to leave enough space above the device. Do not place any object on the device. Avoid exposing the device to vibrations or shocks.





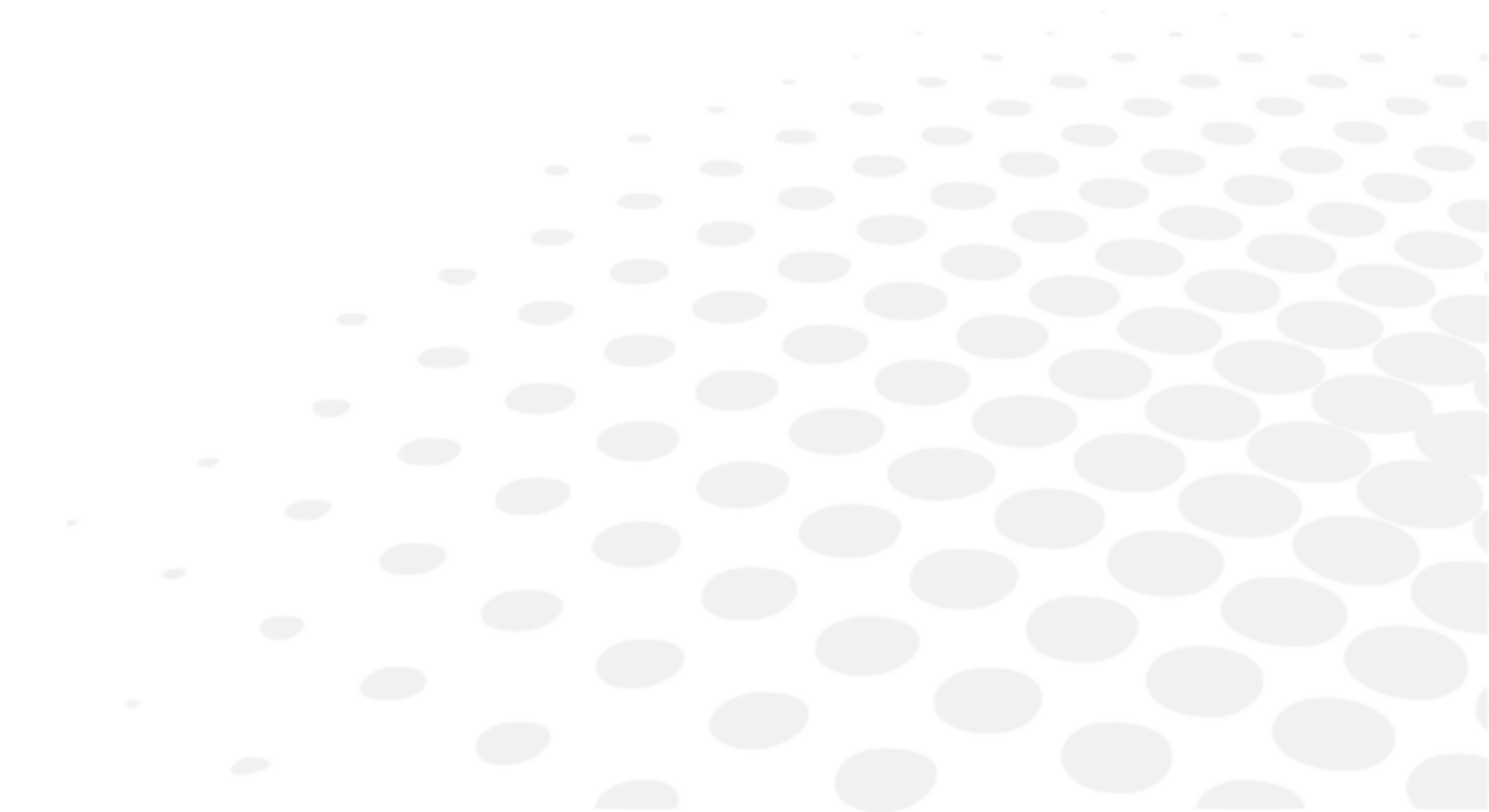

The back of your machine must be at least 20 cm away from a wall.







GENERAL INFORMATION



- Description of the symbols (p.126)
- Modifications (p.126)
- Compliance (p.126)
- Copyright (p.126)
- Materials and products (p.126)
- Security (p.127)
- Electromagnetic waves (p.127)
- License agreement for M'EYE Sign™ (Engraving) software (p.127)

Symbols

SYMBOLS PRESENT ON THE DIGITAL SYSTEM	
O	Off (power)
I	On (power)
	Synchronous motor speed
	asynchronous motor speed
	Caution: risk of electric shock
	Caution: danger, refer to the user manual

SYMBOLS PRESENT IN THE DOCUMENT	
	Danger: risk of injury
	Caution: risk of damage for the machine or the lens
	Note: additional information
	Tip: practical advice for use
	Glossary: indicates a word defined in the glossary
	See also: indicates the page number to consult for further information

Modifications

The information contained in this document is non-contractual and provided as a guide. It is subject to change without prior notice. Errors or omissions may occur in this type of document, although the greatest care has been taken to ensure the accuracy of the information provided. Essilor cannot be held responsible for any malfunction or loss of data resulting from such errors or omissions.

Declaration of conformity

Complies with marking: **CE**

Complies with ISO 16284 standards, IEC 61010-1 and IEC 61326-1 and with directives 200/42/CE, 2014/30/UE, 2014/35/UE.

This equipment complies with the limits imposed by Part 15 of the FCC rule. Its use meets the following conditions: (1) this device must not cause interference and (2) must accept interference from external sources, notably that liable to cause malfunctions.

In accordance with the requirements of FCC rules, any modification made to this equipment which is not expressly approved by ESSILOR INTERNATIONAL would nullify the user's right to use this device.

This equipment has been tested and is deemed compliant with the limits imposed for Class-B digital devices according to Part 15 of the FCC rule. Those limits are set so as to ensure reasonable protection against interference in a residential environment. This equipment generates, uses and may emit radiofrequency energy liable to interfere with radio communications if the device is not installed and used in strict compliance with manufacturer instructions. However, nothing guarantees the absence of interference under particular conditions. If this equipment is the source of interference with radio or television reception (this can be confirmed by switching off the device then turning it back on), the user may be able to eliminate this interference through one or more of the following measures:

- Swivel or move the affected receiver or its receiving antenna;
- Move the device away from the affected receiver;
- Connect the device to a different circuit to that powering the affected receiver;
- Request help from the retailer or a qualified radio / television technician.

Copyright

Copyright © 2016 Essilor - Original manual

All rights reserved. All reproduction of the content of this document, whether in part or as a whole, for the purpose of its publication or dissemination by any means and in any format whatsoever, even free of charge, is strictly prohibited without Essilor's prior written consent.

Materials and products

All edgers obtain a final shape on a lens, by removing material. This process generates dust, which depends on the lens and the materials used.

The materials used for coating the Essilor wheel and consumed during its use are not toxic or allergenic. Nevertheless, users must check that the ground materials are not toxic.

The edger significantly limits dust emissions due to its integrated devices: operation in a closed machine and edging in a wet environment.

Do not place this machine in a dusty environment, in a room where the temperature is too high or too low, or in a wet place.

Safety instructions:

All mechanical or electronic adjustments and electrical maintenance must be carried out by a customer service technician approved by Essilor.

The use of an accessory or a cable other than those recommended in this manual can be dangerous for users.

Keep the power cables and the solenoid valve/pump cables away from sources of heat, sharp objects and grease.

Check the power cable regularly; if damaged, have it replaced by an approved repairer.

Do not use your system in any way other than described in this document. Otherwise, the protection provided by the device could be compromised.

Never try to modify or dismantle this product yourself. In addition to the fact that you are likely to damage the instrument, you can also injure yourself.

Your digital system must be carefully maintained, in accordance with the instructions detailed in this document.

Your system is an electrical appliance compliant with the applicable safety standards. In the event of malfunction, repairs must be carried out by qualified personnel approved by Essilor. Otherwise, user safety is likely to be compromised.

In the event of a long period of non-use and before maintenance and/or replacement of certain accessories, you must unplug your system from the mains.

The equipment must be plugged into an earthed power supply. The earth connection must comply with public standards and be checked by a technician. Avoid using extension cables or adaptors which could create a poor contact.

Never pull on the cables to unplug them from the power socket.

Before connecting your digital system to the mains, ensure that the switch is set to OFF or 0.

If the switch no longer operates ON/OFF (0/I) you must stop using your digital system. Defective switches must be replaced by an approved repairer.

Your system is a professional tool which must only be used by specialized, responsible operators. It must not be used by anyone apart from these operators.

This machine is neither adapted nor intended to operate in an environment where there is a risk of explosion. Do not use this system in the presence of liquids or flammable gases.

Make sure that the equipment is connected to a mains supply which complies with standard NFC 15-100. In addition, make sure that the plug type is 3-pin 10/16 A (earthed) protected by a high sensitivity differential circuit-breaker, maximum 30 mA, and that the wall outlet is easy to access.

It is strongly advised to wear gloves to protect your hands when you empty the tank to clean it.

Electromagnetic waves

Electromagnetic waves emitted by television sets or radios, mobile phones, radio transmitters, etc. are liable to cause malfunctions in the instrument. This instrument is also liable to interfere with television sets or radios, mobile phones, radio transmitters, etc. Avoid installing or positioning devices which may create interference near the instrument. Likewise, never place the instrument on or near this type of device. This could generate malfunctions or faults in the instrument.

Interference and micro-outages

The products have been designed to withstand interference and operate despite its presence and the possibility of micro-outages on the network.

However, if these malfunctions are too serious and abnormal, the machine cannot be guaranteed to operate normally.

License agreement for M'EYE Sign™ (Engraving) software

Please read this licence agreement closely before using the m'eye sign™ software, by using this software, you acknowledge being bound by the terms of this licence, unless otherwise agreed. If you disagree with the terms of this license, do not use the software.

General information

Essilor International (hereafter called "Essilor") grants you a license for use of its M'Eye Sign™ software exclusively for the use set out in these terms and conditions. Essilor reserves all rights which are not expressly granted to you. Rights granted by the terms of this license and its updated version (available at the following address: <http://www.mleiyceesnicgen.com/fr>), apply to possible software updates used to replace and/or complete and/or correct the original M'Eye Sign™ software (hereafter "Software"), unless these updates have a separate license.

You acknowledge having been informed that the installation of the M'Eye Sign™ software requires an internet connection. Essilor does not guarantee that the connection will be uninterrupted and does not guarantee that it will work or the quality of the connection.

Accepted use of the Software and restrictions

A. Subject to the conditions set forth herein, Essilor grants you a personal, non-exclusive, non-transferable license to use the Software for purposes of engraving eligible lenses. The Software must be used exclusively for your professional activity as an optician to enable you to engrave your customers' lenses, in strict compliance with standards and applicable regulations, especially with respect to the field of vision.

B. You can neither rent, nor lease, nor lend, nor redistribute, nor grant licenses to the Software.

C. You are not authorized, and you agree not to authorize a third party: to copy the Software, nor to decompile it, nor to change the programming, to dismantle it, to attempt to derive the source code from it, to decrypt it, to modify it or to create derived products from it (unless these restrictions are prohibited by current legislation). Failure to comply with any of these conditions constitutes a violation of Essilor's rights.

D. The Software contains an existing image database, property of Essilor or free of copyright, as well as an alphabet allowing words to be engraved on the lenses.

In no case may the Software be used to reproduce words, initials, signs, logos, fonts, images or other creations protected by copyright or other intellectual property rights belonging to a third party, without valid authorization from the third party.

E. You are authorized to use the Essilor brand M'Eye Sign™ solely for the purpose of identifying and/or promoting the engraving function to your customers and prospective customers, for the duration of this license and in the exclusive interest of Essilor. You acknowledge that the right of use which has been granted to you does not give you any claim to the intellectual property rights of the M'Eye Sign™ brand, which remain the exclusive property of Essilor. The use of the brand must comply with the graphic charter of the brand M'Eye Sign™ and any directive or recommendation from Essilor or its subsidiaries.

Liability

You acknowledge that the use of the letters of the alphabet and/or the aforesaid images together or combined with one or more letters from the alphabet is done so at your own risk.

Accordingly, you agree to defend and hold harmless Essilor and its subsidiaries from liability regarding any claim or complaint, including legal fees and court costs, which may be brought based on your use of the Software, a breach on your part of this license, a violation on your part of applicable law, or an infringement on your part of the rights, specifically the intellectual property rights, of another natural or legal person.

Disclaimer of warranties

No verbal or written advice, declaration or observation from Essilor or its subsidiaries may be interpreted as a warranty hereunder. Essilor has done its utmost to develop quality software.



However, you expressly acknowledge and accept that the use of the software is at your own risk and that you assume the entire risk regarding quality, performance, accuracy and the handling of the software. The software is provided "as is" without any warranty of any kind. By this license, Essilor excludes all express, implied or legal warranties, including but not limited to implied warranties of merchantability, satisfactory quality, fitness for a particular purpose, quiet enjoyment and non-infringement of third party rights, relating to the software. Essilor in no way guarantees the absence of problems during the use of the software, nor that the software will function without interruption or errors, nor that software faults will be corrected

Limited liability

To the fullest extent permitted by the law, Essilor will not be held liable for any accidental, special, indirect or incidental damage, including but not limited to damage such as lost profits, loss of clients, loss of data, interruption of activities or any other commercial damage, commercial loss resulting from or relating to your use or your inability to use the Software, even if Essilor has been informed of the possibility of such damage.

Termination

This license is granted for an unlimited time. It may be terminated by you or Essilor with 3 months notice. Your rights arising from this license will be immediately terminated without further notice from Essilor if you do not comply with the conditions of the license. As soon as the license is terminated, you must stop using the Software and Essilor will be authorized to remotely erase the Software from any equipment in your possession, to which Essilor has access (via Essibox®).

Applicable law

This license is subject to French law.

Entirety of the agreement; authentic language

This license constitutes the entirety of the agreement between the parties regarding the use of the Software which is the object of the license, and replaces all prior or current written or verbal proposals or agreements on this subject. Any translation of this license is carried out for local needs. In the event of contradiction between the French version and any other version, the French version will prevail.

GLOSSARY

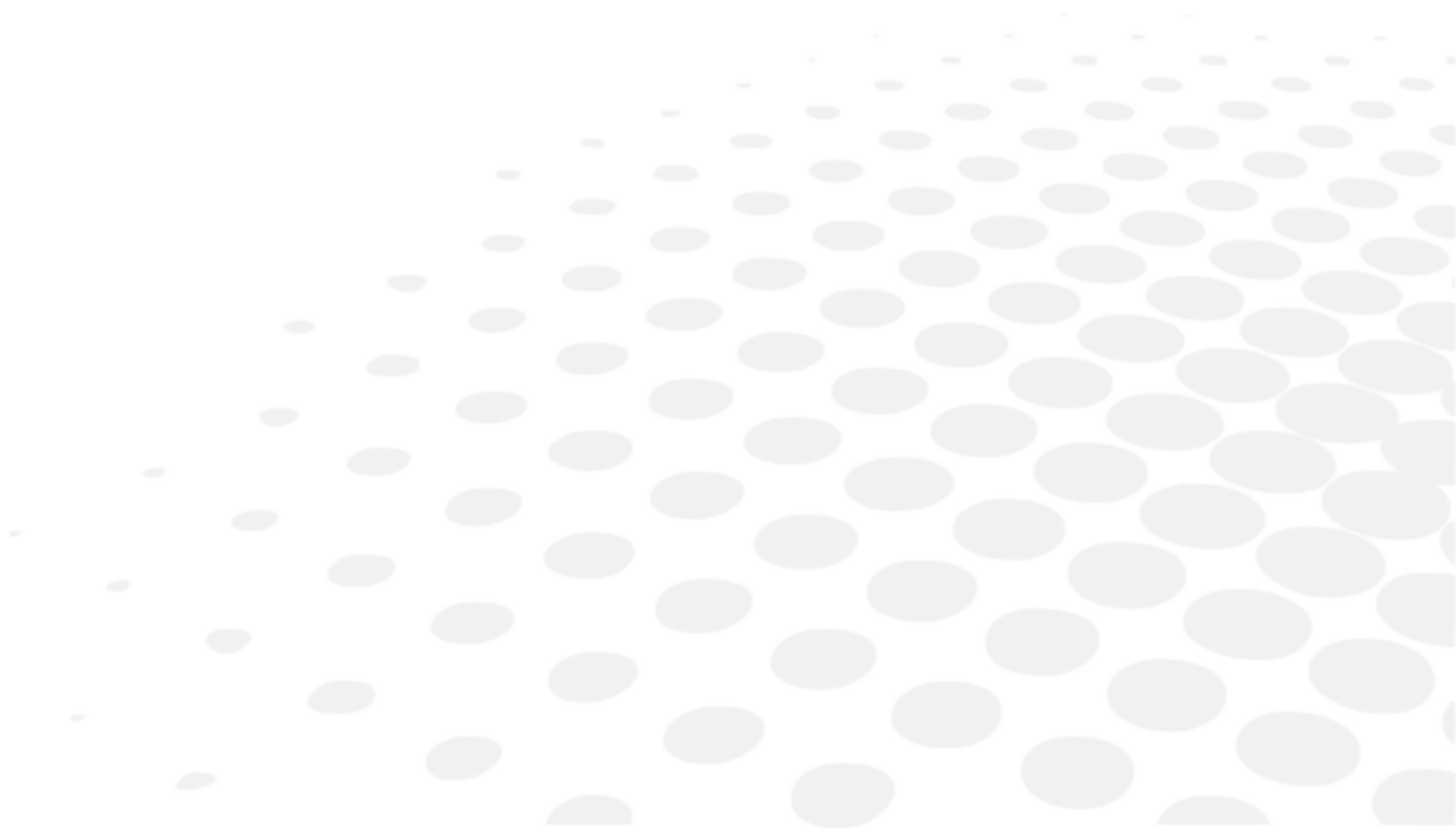

EXECUTIVE LENS

Type of bifocal lens with two full fields: one which corrects far vision defects and one which corrects near vision defects. They are available in two models:

- separation line present on the front surface of the lens
- separation line present on the rear surface of the lens
- Example of lenses of this type: Telex lenses™

GROOVE WITH MENISCUS

The curve of the rim of the frame is considerable.

JOB

All of the actions to be carried out together on the tracer and the edger to manufacture a pair of glasses. It is recorded in the shape management screen under a specific identifier.

LENTICULAR LENS

Type of lens equipped with a small curved optical zone on front or back surface and whose edge is gradually flattened. The correction is in the central part.

REFRACTIVE INDEX

Characterizes the refractive power of a transparent optical material.

The indices vary according to the materials used for the lenses:

- Plastic lens: 1.5
- Polycarbonate lens: 1.59
- Medium or High Index lens: > 1.5
- Trivex™ lens: 1.5 to 1.6
- Tribrid™ lens: 1.6
- Glass lens: 1.5 to 1.9



Essilor Instruments USA
8600 W. Catalpa Avenue, Suite 703
Chicago, IL 60656
Phone: 855.393.4647
Email: info@essilorinstrumentsusa.com
www.essilorinstrumentsusa.com